

EV Charger Selection Guide

» *Always for your safety*



Always for your safety



COMPANY INTRODUCTION

Zhejiang ETEK Electrical Technology Co., Ltd. (Abbreviation: ETEK Electric) is a professional manufacturing company dedicated to the research, development, production, and sales of low-voltage electrical appliances. The company was established in 2011 and is located in Wenzhou City, Zhejiang Province. At present, the company has 40K sqm of modern manufacturing bases in Wenzhou and Wuhu with over 500 employees, including over 50 R&D and technical personnel. ETEK Electric has multiple production workshops for mold design, parts manufacturing, welding, and assembly. Additionally, they have multiple automated production lines for MCB and RCCB. Our products include MCB, RCCB, RCBO, AFDD, MCCB, ACB, EV Chargers, Photovoltaic DC products, etc., which can meet the needs of different countries and are widely used in fields such as residential, commercial, and industrial.

Beginning in 2018, ETEK Electric began to invest heavily in the research and development of new energy products. After more than two years of unremitting efforts, the new sub-brand "ETEC" EV Charger products were officially put into production. protection, safety and reliability; humanized design, convenient operation; excellent applicability, simple installation, economical and practical. At the same time, combined with the continuous improvement of the international and domestic markets, especially the European Union's charging standards for new energy electric vehicles, combined with the requirements of the IEC61851 standard, the company independently developed the latest generation of controllers. The product has a DLB current balance working mode, real-time monitoring of the main circuit current, and automatic adjustment of output charging. current, effectively protecting the electricity safety of the main current circuit. The company has also researched and developed the controller system of OCPP2.0 communication protocol to provide convenient and effective technical support for the operation of charging piles.

ETEK Electric has passed ISO9001 quality management system and environmental management system certification. The company have built our own low-voltage electrical testing center, and most of the testing items can meet the requirements of international IEC standards, in addition, our products have obtained international CB, TUV, VDE, CE, RoHS and other quality certificates.

We also support OEM, ODM, OBM, SKD, CKD and other business cooperation models, and provide customers with a full range of services covering market cultivation, technical training, and factory construction.

Looking forward to the future, ETEK Electric will be committed to becoming a globally renowned manufacturer in the power distribution and electrical industry, safeguarding the power safety of global customers, and helping the development of green and digital energy.



WORKSHOPS



INTERNATIONAL CERTIFICATION



CONTENTS

EKEC1 EV Charging Station	01
EKEC2 Portable EV Charger	03
EKEC4 EV Charging Station	05
EKEC5 EV Charging Station	06
EKEC6 EV Charging Station	07
EKDCC1 20-40kW Small DC EV Charging Station	08
EKDCC2 30-320kW Fast DC EV Charging Station	10
EKDCC3 60-320kW Three-Gun-Charger Customized version	12
EKEPC2 Mode 3 EV Charge Controller	14
EKEPC3 Modular EV Charger OCPP Protocol Controller	17
EKEPCB1 Mode 2 EV Charge PCB Board	20
EKEPCB2 Mode 3 EV Charge PCB Board	21
EKEPCB3 Mode 3 EV Charge PCB Board	22
EKRCMU-1 RCMU Residual Current Monitoring Unit	23
EKEL AC Charging pluse Electronic Lock	26
RFID Module and Cards/ LCD Display	27
CTKD24 Open-type Current Transformer	28
EKEP AC Charging Station Plug	29
EKEPDC CCS Type2 DC Charging Plug	30
EV Chagring Adapter	31
EV Chagring Socket	32
EV Chagring Empty Socket	33
V2L Discharge Plug	34
EV Charging Accessory	35
RCCB Type B EKL1-63B Residual Current Circuit Breaker	36
RCCB Type B EKL6-100B Residual Current Circuit Breaker	37
RCCB Type EV EKL6-63EV Residual Current Circuit Breaker	38
ETEK RCCB Main Technical Parameters	39
RCBO Type B EKL5-63B RCCB with Overcurrent Protection	41
RCBO Type EV EKL5-63EV RCCB with Overcurrent Protection	42
ETEK RCBO Main Technical Parameters	43
EKMF Modular Contactor	45
EKEM2D Single Phase Smart Meter	49
EKEM4D Three Phase Smart Meter	50



IP54	IK08			
Protection Level	Impact-resistant Level	Corrosion Resistant	Flame Retardant	Modular Design

Overview

EKEC1 is a mode 3 charging device that provides full support for all electric vehicles. Its unique feature is that the controller module is equipped with a variable current selector, giving customers the flexibility to choose from five different charging levels. The product series includes two major categories: cable version and socket version to meet the changing needs in different scenarios.

In terms of design, EKEC1 follows rigorous industrial design principles and can be quickly installed in homes and commercial places. At the same time, the protection level of the whole machine reaches the IP54 standard, ensuring that it has excellent dust and water resistance, providing users with a stable and reliable charging experience.

Features

- Adjustable charging current values 10A, 16A, 20A, 25A and 32A.
- Rated power up to 22kW (three-phase 32A).
- Support OCPP-1.6-J charging protocol (requires EKEPC3 controller).
- Multiple protections can be achieved through different combinations of internal components, safe and reliable.
- Internal components are modular devices, easy to maintain.
- Two versions: cable version and socket version.
- IK08 or higher impact-resistant design

Product selection



Code	Meaning
①	Product design model
②	S2: Socket with lock C1: T1 Cable C2: T2 Cable SS: Socket with Lock & Shullter
③	03: Single phase: 1P+N, 240, 16A, 3.6kW 07: Single phase: 1P+N, 240, 32A, 7.3kW 11: Three phase: 3P+N, 420V, 16A, 11kW 22: Three phase: 3P+N, 420V, 32A, 22kW
④	O: Built in EKEPC3 controller M: Built in EKEPC2 controller

Code	Meaning
⑤	A: Type A RCCB + DC 6mA RCMU B: Type B RCCB C: Type EV RCCB D: Built-in DC 6mA RCMU (this configuration requires an additional Type A RCCB to be installed in the charging pile power distribution box)
⑥	1: RFID function (if the built-in EKEPC3 controller is used, this function is required) 2: DLB function external CT (only supports single-phase circuit) 3: DLB function external energy meter 4: LCD display 5: Built in MID meter 6: Built in SPD (only applicable for single-phase circuit) 7: With emergency stop button 8: With PEN protection

If you need a charging post to meet the following configuration: European Standard Cable version 22KW. Using TypeA RCCB + DC6mA+ OCPP-J-1.6 protocol + LcD display + meter, then its model is: EKEC1-C2-22-0-A-145

Technical Data

Model	Cable type		Socket type	
	EKEC1-C1/C2-03-X-X-XXX EKEC1-C1/C2-07-X-X-XXX	EKEC1-C1/C2-11-X-X-XXX EKEC1-C1/C2-22-X-X-XXX	EKEC1-S2/SS-03-X-X-XXX EKEC1-S2/SS-07-X-X-XXX	EKEC1-S2/SS-11-X-X-XXX EKEC1-S2/SS-22-X-X-XXX
Operation Voltage	AC220V±10% (L+N+PE)	AC420V±10% (3P+N+PE)	AC220V±10% (L+N+PE)	AC420V±10% (3P+N+PE)
Max. output current	16A	32A	16A	32A
Max. output power	7.3kW	22kW	7.3KW	22KW
Charging current	5 levels adjustable 10A, 16A, 20A, 25A, 32A			
AC power frequency	50Hz±1Hz			
Standby power	<8W			
Cable length	5m (Supports customization of other lengths)		-	
Connector Type	SAE J1772, IEC 62196-2, GB/T			
Communication	Support Modbus-RTU protocol and OCPP-1.6-J protocol			
RCD Type	Type A / Type B / Type A+6mA DC			
Overvoltage Category (OVC)	OVC III			
Insulation resistance	>10MΩ			
AC withstand voltage	2.8kV			
Electrical protection classes	Class I			
Protection grade	IP54			
Pollution degree	3			
Operating temperature	-20°C~+50°C			
Storage temperature	-40°C~+70°C			
Relative humidity	5%~95%			
Altitude	≤2000m			
Cooling method	Natural cooling			
Mounting Method	Wall-Mounted / Ground-mounting Pole			
Wiring method	Bottom-in and bottom-out			
Dimension(L/W/D)	357mm×245mm×123mm			

Overall Installation Drawing (mm)

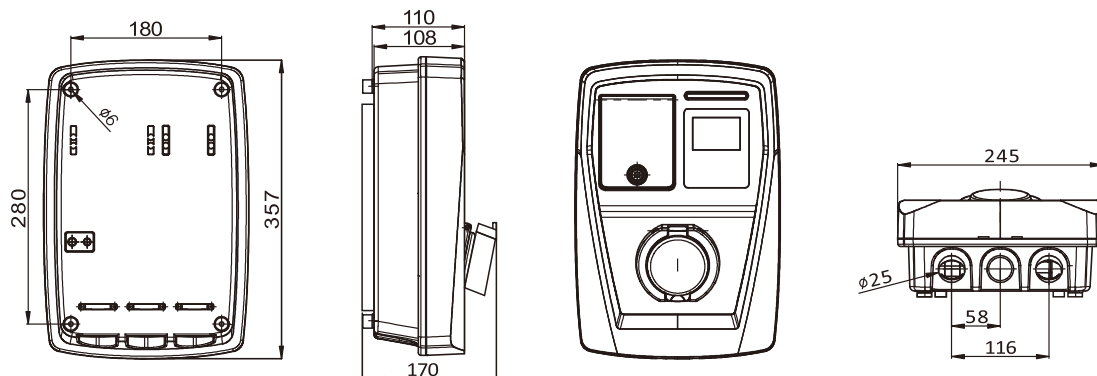



Protection Level



Impact-resistant Level



Corrosion Resistant



Flame Retardant



Multiple Protection



Style A



Style B



Style C



Style D

Overview

The EKEC2 EVSE (Electric Vehicle Supply Equipment) portable charger is a charging device specially designed according to IEC 62752, IEC 61851-1 standards, consisting of a control box, charging connector, plug, etc., which is a portable electric vehicle charging device. The device delivers up to 22kW output power.

The distinctive feature of this device is its portability and efficiency, allowing car owners to charge electric vehicles through standard household power interfaces at any location, thus ensuring the convenience and flexibility of charging.

Features

- Rated power up to 22kW (32A three phase)
- Multiple current levels are adjustable to meet different charging needs
- Schedule charging at scheduled times and charge at off-peak hours to save money
- Multiple protection functions, safe and reliable
- LED indicator + LCD screen dual display to accurately control charging status
- IP65 waterproof and dustproof, easy to charge in harsh environments
- Corrosion resistant and flame retardant
- IK10 level impact resistant design

Technical Data

Style	Style A&B		Style C&D	Style D
Rated Power	3.6kW	7.3kW	11kW	22kW
Rated Voltage	240V±10%		AC420V±10%	
Max. output current	16A (6-8-10-13-16, Adjustable)	32A (6-8-10-13-16-20-25-32A, Adjustable)	16A (6-8-10-13-16, Adjustable)	32A (6-8-10-13-16-20-25-32A, Adjustable)
AC power frequency	50Hz			
Standby power	<8W			
Display Mode	LED indicator + LCD display			
Plug cable length	1m			
Total length	Standard 5m (customizable)			
Terminal Connection	Schuko / UK / CEE / NEMA / AU			
Connector Type	SAE J1772, IEC 62196-2, GB/T			
RCD Type	Type A / Type A+6mA DC			

Overvoltage Category (OVC)	OVC III
Insulation resistance	>10MΩ
AC withstand voltage	2.8kV
Electrical protection classes	Class I
Ingress Protection	IP65
Pollution degree	3
Impact Protection	IK10
Electrical Protection	Under Voltage Protection / Over Load Protection / Short Circuit Protection / Earth Leakage Protection / Over-temp Protection /Lightning Protection
Operating Temperature	-30°C~+55°C
Storage temperature	-40°C~+70°C
Relative humidity	5%~95%
Operating Altitude	≤2000m
Cooling method	Natural cooling
Mounting Method	Plug and charge

Power Plug Type

Type A	Type B	Type C	Type E	Type D	Type F
Type G	Type H	Type I	Type J	Type K	Type L
Type M	Type N	Type O	Regular type industrial plug	SCHUKO type industrial plug	

Note: 7kW, 11kW, 22kW only support CEE plug or Schuko plug

Overall Installation Drawing (mm)

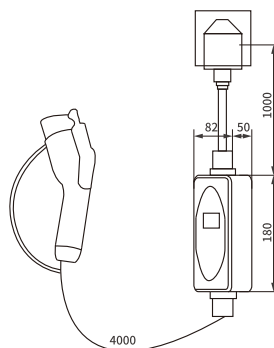



Dimension (mm)

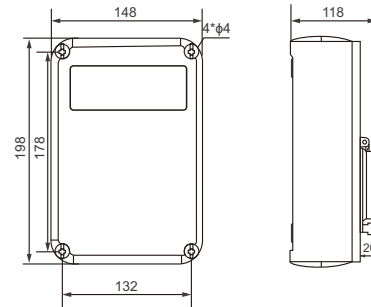

Technical Data

EV charging modes	Mode 3 Charging	
Power supply	1P+N+PE	3P+N+PE
Rated voltage	AC 240V±10%	AC 420V±10%
Rated power	3.6kW, 7.2kW	11kW, 22kW
Rated current	Max 16A, Max 32A	
Rated frequency	50Hz	
Over voltage category (OVC)	OVC III	
Insulation resistance	R>1 MΩ	
AC withstand voltage	1430V	
Impulse dielectric withstand voltage (1,2 μs/50 μs)(uimp)	4kV	
Protection against electric shock	Class I	
Electrical life (Contactor)	100,000	
Electrical life (Interface)	100,000	
Standby power consumption	<8w	
Type of EV connection	Case B (Socket version)/ Case C (Cable version)	
Universal interface	T1: SAE J1772; T2: IEC/EN 62196-2, GB/T: 20234.2-2015	
Support protocol	Modbus-RTU	
Functional	DLB, LED, LCD, RFID	
Protection	RDC-DD DC6mA; Over temperature protection	
Pollution degree	PD 3	
Ip protection class	IP54	
Altitude during operation (m)	<2000m	
Altitude of test laboratory	<50m	
Work humidity	3%~95%	
Operation temperature	-25°C~55°C	
Cooling	Natural air cooling	
Mounting method	Mounted on walls, poles or equivalent positions	
Normal environmental conditions	Indoor use; Outdoor use	

The AC charging station needs an external MCB+type A type RCCB/Type A RCBO to be installed in the upstream distribution box



Dimension (mm)

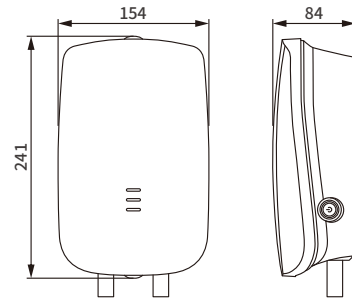

Technical Data

EV charging modes	Mode 3 Charging	
Power supply	1P+N+PE	
Rated voltage	AC 240V±10%	
Rated power	3.6kW, 7.2kW	
Rated current	Max 32A	
Rated frequency	50Hz	
Over voltage category (OVC)	OVC III	
Insulation resistance	R>1 MΩ	
AC withstand voltage	1430V	
Impulse dielectric withstand voltage (1,2 μs/50 μs)(uimp)	4kV	
Protection against electric shock	Class I	
Electrical life (Contactor)	100,000	
Electrical life (Interface)	100,000	
Standby power consumption	<8w	
Ocpp1.6J protocol	Support ethernet/ Wifi communication	
Type of EV connection	Case C (Cable version)	
Universal interface	T1: SAE J1772; T2: IEC/EN 62196-2, GB/T: 20234.2-2015	
Support protocol	Basic type	Modbus-RTU
	Commercial type	OCPP1.6J
Functional	Basic type	DLB, LED, LCD, RFID, Integreted metering on board
	Commercial type	DLB, LED, LCD, RFID, Integreted metering on board, OTA Firmware update, Embedded website, Wifi/4G/Ethernet communication
Protection	Basic type	RDC-DD DC6mA; Under/Over voltage protection Over Current protection; Over temperature protection
	Commercial type	RDC-DD DC6mA; Under/Over voltage protection Over Current protection; Over temperature protection
Pollution degree	PD 3	
Ip protection class	IP54	
Altitude during operation (m)	<2000m	
Altitude of test laboratory	<50m	
Work humidity	3%~95%	
Operation temperature	-25°C~55°C	
Cooling	Natural air cooling	
Mounting method	Mounted on walls, poles or equivalent positions	
Normal environmental conditions	Indoor use; Outdoor use	
The AC charging station needs an external MCB+type A type RCCB/Type A RCBO to be installed in the upstream distribution box		



Dimension (mm)

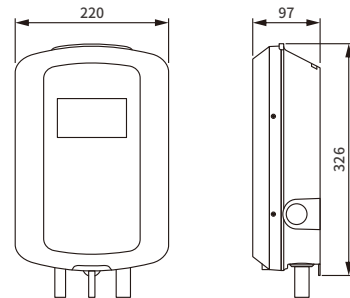

Technical Data

EV charging modes	Mode 3 Charging	
Power supply	1P+N+PE	3P+N+PE
Rated voltage	AC 240V±10%	AC 420V±10%
Rated power	3.6kW, 7.2kW	11kW, 22kW
Rated current	Max 16A, Max 32A	
Rated frequency	50Hz	
Over voltage category (OVC)	OVC III	
Insulation resistance	R>1 MΩ	
AC withstand voltage	1430V	
Impulse dielectric withstand voltage (1,2 μs/50 μs)(uimp)	4kV	
Protection against electric shock	Class I	
Electrical life (Contactor)	100,000	
Electrical life (Interface)	100,000	
Standby power consumption	<8w	
Type of EV connection	Case C (Cable version)	
Universal interface	T1: SAE J1772; T2: IEC/EN 62196-2, GB/T: 20234.2-2015	
Support protocol	Basic type	Modbus-RTU
	Commercial type	OCPP1.6J
Functional	Basic type	DLB, LED, LCD, RFID, Integrated metering on board
	Commercial type	DLB, LED, LCD, RFID, Integrated metering on board, OTA Firmware update, Embedded website, Wifi/4G/Ethernet communication
Protection	Basic type	RDC-DD DC6mA; Under/Over voltage protection Over Current protection; Over temperature protection
	Commercial type	RDC-DD DC6mA; Under/Over voltage protection Over Current protection; Over temperature protection
Pollution degree	PD 3	
Ip protection class	IP54	
Altitude during operation (m)	<2000m	
Altitude of test laboratory	<50m	
Work humidity	3%~95%	
Operation temperature	-25°C~55°C	
Cooling	Natural air cooling	
Mounting method	Mounted on walls, poles or equivalent positions	
Normal environmental conditions	Indoor use; Outdoor use	

The AC charging station needs an external MCB+type A type RCCB/Type A RCBO to be installed in the upstream distribution box



Brief Description

The charging pile adopts simple column design, covers a very small area. It is very suitable for small power charging scenario with site limitation and distribution limitation.

Model Preparation Meaning

EK	DC	C2	-	CC	-	40	-	S	W
↓	↓	↓		↓		↓		↓	↓
①	②	③		④		⑤		⑥	⑦
Code	Meaning				Code	Meaning			
①	ETEK				⑤	Power: 20, 30, 40kW			
②	DC EV Charging Station				⑥	Small DC charging station			
③	C1: 1 charging guns C2: 2 charging guns				⑦	W: Wall mounting Blank: Column/upright mounting			
④	CC: 2*CCS2 or CCS1 charging guns C: 1*CCS2 or CCS1 charging guns G: National standard charging guns J: Japan standard CHAdeMo charging guns								

Technical Data

Power	20kW/30kW/40kW
Connector	GBT/CCS1/CHAdeMO/CCS2 optional
Connector number	Single gun/Double gun (only 40kW)
Input voltage	380V (-25%,+25%) AC
Frequency	50/60Hz
Maximum output current	0-50A(20kW), 0-100A(30kW), 0-125A(40kW)
Output voltage	50V~1000VDC
User Interface	Led Indicator Green/Yellow/Red
	7.0 Inch LCD Display
	RFID Mifare ISO/IEC14443 A
Emergency stop button	Yes
Charge mode	Plug&charge,RFID,APP
Communication protocol	OCPP1.6J or other
Communication	Ethernet/4G/Wifi (4G and wifi optional)
Electrical protection	Over current protection, Short circuit protection, Ground protection, Surge protection, Over/Under voltage protection, Over/Under frequency protection, Over/Under temperature protection
Energy meter	Yes
Certificate standard	EN/IEC 61851-1: 2017, EN/IEC 61851-23: 2014
Ingress protection	IP54
Impact protection	IK08
Work temperature	-30°C~+50°C
Work humidity	5%~95%
Work altitude	<2000m
Product dimension	420×230×620mm (20/30kW); 560×210×770mm (40kW)
Package dimension	455×550×810mm (20/30kW); 1010×720×510mm (40kW)
Net weight	40kg (20kW)/ 50Kg (30kW)/ 75Kg (40kW double gun)
Gross weight	45kg (20kW)/ 55Kg (30kW)/ 78Kg (40kW double gun)
External package	Carton
Installation mode	Floor/wall hanging



Brief Description

The best-selling model at home and abroad, strong compatibility, compatible with 20/40kW module, power range covers 30kW to 320kW.

Model Preparation Meaning

EK	DC	C2	-	CC	-	320	B
↓	↓	↓		↓		↓	↓
①	②	③		④		⑤	⑥
Code	Meaning			Code	Meaning		
①	ETEK			④	CC: 2*CCS2 or CCS1 charging guns C: 1*CCS2 or CCS1 charging guns G: National standard charging guns J: Japan standard CHAdeMo charging guns		
②	DC EV Charging Station			⑤	30kW,40kW,60kW,80kW Frame 80kW 90kW,120kW,150kW,160kW Frame 160kW 180kW,240kW,320kW Frame 320kW		
③	C1: 1 charging guns C2: 2 charging guns			⑥	Power module: A, B, C		

Technical Data

Power	30kW,40kW,60kW,80kW Frame 80kW 90kW,120kW,150kW,160kW Frame 160kW 180kW,240kW,320kW Frame 320kW
Connector	GBT/CCS1/CHAdeMO/CCS2 optional
Connector number	Single gun/Double guns
Input voltage	380V (-25%,+25%) AC
Frequency	50/60Hz
Output voltage	50V~1000VDC
Power factor	≥0.99
Peak efficiency	95.5%
Auxiliary power supply	12V
Humidness	≤95%
Soft startup time	3-8S
Voltage accuracy	≤0.5%
User Interface	Led Indicator Green/Yellow/Red
	7.0 Inch LCD Display
	RFID Mifare ISO/IEC14443 A
Emergency stop button	Yes
Charge mode	Plug&charge,RFID,APP
Communication protocol	OCPP1.6J or other
Communication	Ethernet/4G
Electrical protection	Over current protection, Short circuit protection, Ground protection, Surge protection, Over/Under voltage protection, Over/Under frequency protection, Over/Under temperature protection
Energy meter	Yes
Ingress protection	IP54
Impact protection	IK08
Work temperature	-35°C~+50°C
Work humidity	5%~95%
Work altitude	<2000m
Outer dimension	H:1700×L:700×W:403 Frame 80kW H:1700×L:700×W:530 Frame 160kW H:1800×L:700×W:673 Frame 320kW
External package	Wooden Case
Installation mode	Floor/wall hanging
Certificate Standard	EN/IEC 61851-1: 2017, EN/IEC 61851-24: 2014
Certificate	TUV SUD,CB,CE,UKCA



Brief Description

The three-gun customized model is a DC EV Charging Station with 3 charging points, which can be customized according to customer requirements European standard, China standard, Japanese standard, American standard different power configuration and charging gun GBT / CCS2 / CCS1 / CHAdeMO /T2 /T1/Tesla configuration, DC maximum 300A, AC maximum 22kW.

Model Preparation Meaning

EK	DC	C2	-	CC	-	320	B
↓	↓	↓		↓		↓	↓
①	②	③		④		⑤	⑥
Code	Meaning			Code	Meaning		
①	ETEK			④	CC: 2*CCS2 or CCS1 charging guns C: 1*CCS2 or CCS1 charging guns G: National standard charging guns J: Japan standard CHAdeMo charging guns		
②	DC EV Charging Station			⑤	Power: 60kW, 90kW, 120kW, 160kW, 180kW, 240KW, 320kW		
③	C1: 1 charging guns C2: 2 charging guns C3: 3 charging guns			⑥	Power module: A, B, C		

Technical Data

Power	60kW,90kW,120kW,160kW,180kW,240kW,320kW
Connector	GBT/CCS1/CHAdeMO/CCS2 optional
Connector number	Three guns
Input voltage	380V (-25%,+25%) AC
Frequency	50/60Hz
Output voltage	50V~1000VDC
Power factor	≥0.99
Peak efficiency	95.5%
Auxiliary power supply	12V
Humidness	≤95%
Soft startup time	3-8S
Voltage accuracy	≤0.5%
User Interface	Led Indicator Green/Yellow/Red
	7.0 Inch LCD Display
	RFID Mifare ISO/IEC14443 A
Emergency stop button	Yes
Charge mode	Plug&charge,RFID,APP
Communication protocol	OCPP1.6J or other
Communication	Ethernet/4G
Electrical protection	Over current protection, Short circuit protection, Ground protection, Surge protection, Over/Under voltage protection, Over/Under frequency protection, Over/Under temperature protection
Energy meter	Yes
Ingress protection	IP54
Impact protection	IK08
Work temperature	-35°C~+50°C
Work humidity	5%~95%
Work altitude	<2000m
Outer dimension	H:1700*L:700*W:530 Frame 160kW H:1800*L:700*W:673 Frame 320kW
External package	Wooden Case
Installation mode	Floor/wall hanging
Certificate Standard	EN/IEC 61851-1: 2017, EN/IEC 61851-24: 2014



overview

EKEPC2 is an AC charging pile controller designed for DIN rail installation. As the core intelligent control component of the AC charging pile, it complies with the IEC61851-1 or GB18487.1-2015 standards and can achieve outstanding performance of up to 32A charging current in mode 3.

EKEPC2 supports Modbus-RTU protocol and RS485 communication, has highly flexible expansion capabilities, and is compatible with a variety of devices, including but not limited to contactless IC cards, residual current detection devices (RCMU), DLB current detection devices, LCD displays, energy meters, electromagnetic locks, and external emergency stop buttons. Together, these devices enable the diverse functions of the charging pile, including DLB (dynamic load balancing) and PEN fault protection.

These features provide charging pile manufacturers and installers with a cost-effective solution that can meet charging needs in different application scenarios.

Product Features

- Compliant with IEC 61851-1 standard (mode 3 charging)
- Support Modbus-RTU protocol and RS485 communication method
- Modular design, rail installation
- Configurable master and slave devices
- Adjustable charging current (maximum 32A)
- Equipped with dynamic load balancing management (DLB) function

Technical Data

Model	EKEPC2-C (Socket type)	EKEPC2-S (Cable type)
Operating voltage	AC230V±10%	
Auxiliary output voltage	DC12V/100mA, DC5V/100mA	
Charging mode	Mode 3 according to IEC61851-1 via IEC62196-2 or SAE J1172 (socket or tethered cable outlets)	
Charging current	16A(6-8-13-16A Adjustable), 32A(10-16-20-25-32A Adjustable), 63A(Customized)	
Basic functions	Over-temperature protection	
Additional functions and compatible devices	<ul style="list-style-type: none"> • DC leakage current detection ($\geq 6\text{mA}$), requires external RCMU; • RFID start-stop function, requires an RFID card and an external card reader; • LED charging status display and LCD screen display, external LED lights and LCD screen are required; • Solenoid interlock for socket; • DLB requires an external 100A/5A ratio CT or MID meter; • Real-time monitoring of voltage, current, and power requires an external 100A/5A ratio CT and MID-certified meter; • PEN fault protection, external SPD is required; • Emergency stop function requires an external emergency stop button switch; • Over-voltage, under-voltage, and over-current protection settings need to be configured in the software background. 	

Communication protocol	Modbus-RTU protocol and RS485 communication mode
Operating temperature	-25°C~+50°C
Relative humidity	5%~95%
Altitude	≤2000m
Protection grade	IP22
Cooling method	Natural cooling
Mounting	DIN rail (35mm)

Controller Terminals

Terminal	Description
L	Connects to AC “live” or “line” with 230V±10%@50Hz
N	Connects to AC “neutral” line with 230V±10%@50Hz
P1	A1 Connect to contactor coil A1
P2	A2 Connect to contactor coil A2
FB	Feedback signal of solenoid interlock. If lock feedback is selected, the lock feedback of solenoid interlock is read.
FB (0V)	
MH	Provides a drive current to continuously energize the solenoid interlock. Provides a drive current to change the motorized interlock state to locked, the signal is activated for 500ms and changes to pulse 500ms intervals until the lock is closed. Rating 12V 300mA.
ML	Provides a return path for the solenoid interlock drive current ML. Provides a drive current to change the motorized interlock state to unlocked. Rating 12V 300mA.
0V	0V connection terminal for RCMU and IC card circuit
RED	Connected to the red indicator light, rating 5V 10mA
GRE	Connected to the green indicator light, rating 5V 10mA
BLU	Connected to the blue indicator light, rating 5V 10mA
IC	Connect the input signal of the IC card control to the TTL level signal (DC 3.3V/5V), and connect the other side to the 0V terminal.
FLT	Connect to the RCMU "Fault Out" to read the fault signal from the RCMU.
TST	Connect to the RCMU "Test". The controller sends a test signal to the RCMU before each charging to detect whether the RCMU is working normally.
+12V	12V power supply, Rating DC+12V, 100mA
CT1	Connect to the main circuit CT1. When the controller turns on the DLB function, it is necessary to connect the main circuit CT signal (signal: AC0-5A).
CT2	Connect to the other side of the main circuit, CT1.
PE	Power ground terminal
CP	Control Pin. Connects to the CP of IEC61851/J1772 EVSE socket/plug.
PP	Proximity Pin. Connects to the PP of IEC61851 EVSE socket.
+5V	5V power supply, Rating DC+5V,100mA
A+	They are connected to the A+ and B- ports of RS485 communication respectively and can communicate with RS485 devices. The communication standard complies with the Modbus-RTU mode, baud rate: 9600, n,8,1, and the default address number is: 01.
B-	

DIP Switch Description

To cater to the DIY needs of users, this controller features an integrated DIP switch on the PCB board (the controller cover needs to be removed), which allows users with a certain level of electrical knowledge to more easily implement various additional functions.

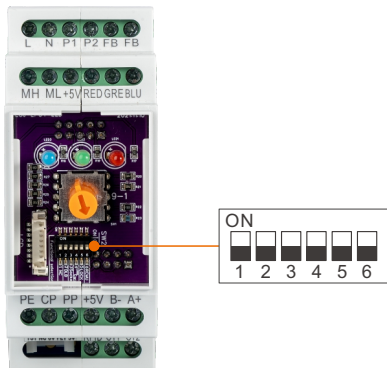

Switch position	No.	Description
ON	1	Led indicator waiting for inspection status
	2	DLB current balance working mode
	3	Socket version working mode
	4	Function with RFID
	5	With electronic lock function
	6	Added RCMU(DC6mA) module function
OFF	1	No Led indicator waiting for inspection status
	2	Normal DLB balance working mode
	3	Cable version working mode
	4	Lost (without) IC card working mode
	5	Without electronic lock function
	6	None RCMU(DC6mA) protection function

Overall and Installation Dimension(mm)

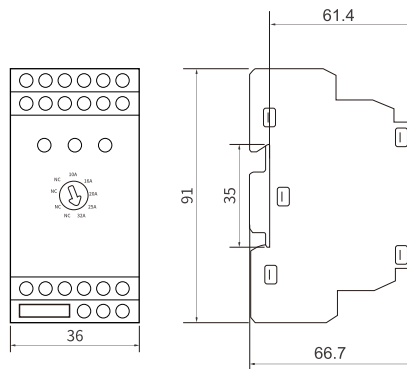



overview

EKEPC3 charging controller is a highly integrated and intelligent modular electric vehicle charging controller that complies with the IEC61851-1 standards and can provide up to 32A of charging current in mode 3.

EKEPC3 charging controller allows users to remotely monitor the charging status, start and stop charging, set charging time, and adjust charging power through a web portal. It can also implement load management strategies to prevent grid or circuit overload and optimize power distribution in multi-charging point systems. Additionally, the EKEPC3 controller provides authentication functions (such as RFID, PIN code), ensuring the safety and convenience of charging operations.

EKEPC3 charging controller is equipped with built-in OCPP-J-1.6, 4G, Wi-Fi (2.4G), and Ethernet modules, enabling it to easily communicate with various backend systems and access payment, load management, charging scheduling, and access control functions provided by the platform. Additionally, the controller supports OTA firmware updates to introduce new features, improve performance, or address potential security vulnerabilities in a timely manner.

EKEPC3 charging controller is a reliable solution for creating smart charging sites for electric vehicles, suitable for both home and commercial applications.

Product Features

- Comply with standard IEC61851-1 (mode 3 charging)
- Supports 1 outlet, Socket, or tethered cable
- Provide three working modes: host, slave, and master-slave
- Support OCPP-J-1.6, Modbus RTU protocol, 2.4G Wi-Fi, Ethernet, RS485 communication
- Modular design, 35mm DIN rail mount
- Adjustable charging current (maximum 32A)
- Status LED and external LED, LCD support
- RFID access control support
- RCM support for >6mA DC leakage current
- PEN fault protection
- With dynamic load balancing management (DLB) function
- OTA firmware update

Technical Data

Model	EKEPC3
Operating voltage	170-260V @ 50/60Hz AC
Auxiliary output voltage	DC12V/100mA, DC5V/100mA
Power consumption	≤3W
Charging mode	Mode 3 according to IEC61851-1 via IEC62196-2 or SAE J1172 (socket or tethered cable outlets)
Charging current	Max. 32A (1~32A, Adjustable)
Basic functions	Over-temperature protection (threshold 95°C)
Additional functions and compatible devices	<ul style="list-style-type: none"> • DC leakage current detection ($\geq 6\text{mA}$), requires external RCMU; • RFID start-stop function, requires an RFID card and an external card reader; • LED charging status display and LCD screen display, external LED lights and LCD screen are required; • Solenoid interlock for socket; • DLB requires an external 100A/5A ratio CT or MID meter; • Real-time monitoring of voltage, current, and power requires an external 100A/5A ratio CT and MID-certified meter; • PEN fault protection, external SPD is required; • Emergency stop function requires an external emergency stop button switch; • Over-voltage, under-voltage, and over-current protection settings need to be configured in the software background.
Communication protocol	OCPP-J-1.6, Modbus RTU protocol, 2.4G Wi-Fi, Ethernet, RS485 communication
Operating temperature	-25°C~+50°C
Relative humidity	5%~95%
Altitude	≤2000m
Protection grade	IP22
Cooling method	Natural cooling
Mounting	DIN rail (35mm)

Controller Terminals

Terminal	Description
L	Connects to AC “live” or “line” with $230\text{V} \pm 10\% @ 50\text{Hz}$
N	Connects to Ac “neutral” line with $230\text{V} + 10\% @ 50\text{Hz}$, Connect to contactor A1 terminal.
P1, P2	<p>P1 and P2 are passive output contacts, providing 250VAC/2A output capacity.</p> <p>P1 is connected to the power supply L terminal, and P2 is connected to the contactor A2 terminal.</p>
PP	Proximity Pin. Connects to the PP of IEC61851 EVSE socket.
CP	Control Pin. Connects to the CP of IEC61851/J1172 EVSE socket/plug.
PE	Power ground terminal
RCMU	RCMU residual current sensor connection terminal, connected using the connection line provided with the RCMU module.
0V	0V connection terminal
5V	5V power supply, Rating DC+5V,100mA

MH	Provides a drive current to continuously energize the solenoid interlock. Provides a drive current to change the motorized interlock state to locked, the signal is activated for 500ms and changes to pulse 500ms intervals until the lock is closed. Rating 12V 300mA.
ML	Provides a return path for the solenoid interlock drive current ML. Provides a drive current to change the motorized interlock state to unlocked. Rating 12V 300mA.
FB FB(0V)	Feedback signal of solenoid interlock. If lock feedback is selected, the lock feedback of solenoid interlock is read.
B- A+	They are connected to the A+ and B- ports of RS485 communication respectively and can communicate with RS485 devices. The communication standard complies with the Modbus-RTU mode, baud rate: 9600,n,8.1, and the default address number is: 255H.
SIM-CARD	SIM card slot supports multiple network standards and frequency bands. LTE-FDD: B1/B3/B5/B8 LTE-TDD: B34/B38/B39/B40/B41 GSM/EDGE: B3/B8
WIFI (2.4G)	SIM card slot supports multiple network standards and frequency bands.
4G	4G patch antenna interface (824-2170MHz)
LCD	External LCD display interface
LED-OUT	External LED status indicator interface
WAN	WAN port: wide area network port
R-G-B-Y	Charging Status Indicator Position Marker

Overall and Installation Dimension(mm)

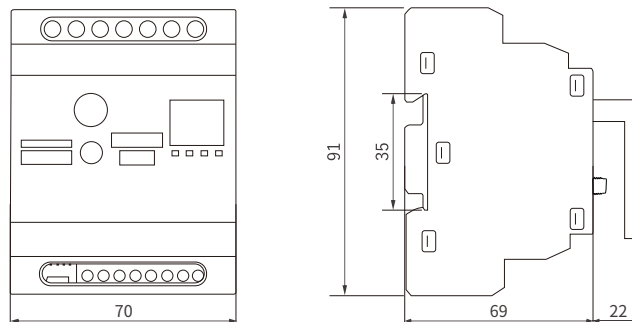

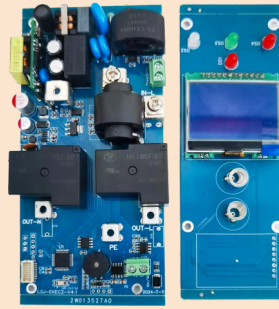

Brief Description

EKEPCB1 is using for mode 2 portable EV charger complies with IEC61851-1 or SAEJ1772 standard, input voltage is 230V~, max current up to 32A, charging current can selection, it has functional of status indicating, LCD display, charging time reservation, free PE connection, protection of over temperature, over/under voltage, over current and residual current current protection AC30mA+DC6mA.

Technical Specification

Model	EKEPCB1-C
Mode	Mode 2 charging
Operating voltage	AC230V \pm 10%, 50Hz
Output the PWM signal	Max: 16A, 6A/8A/10A/13A/16A adjustable Max: 32A, 6A/8A/10A/13A/16A/20A/25A/32A adjustable
Basic function	<ul style="list-style-type: none"> • IEC62955 standard AC 30mA and DC6mA leakage monitoring • Overtemperature protection • Overvoltage & undervoltage protection • Over current protection • Voltage, current, Power for real time monitoring
Additional function	LCD display function with an auxiliary device of LCD screen
Output auxiliary voltage	DC12V/100mA, DC5V/100mA
Ambient temperature	-40°C ~ +50°C
Humidity	\leq 85%
Cooling method	Natural cooling
Installation method	PCB mounted

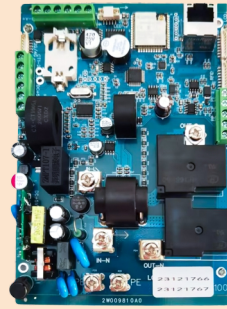

Brief Description

EKEPCB2 is using for AC EV Charging Station complies with IEC61851-1 or SAEJ1772 standard and PCB installation requirement.

The output of the controller adopts relay switching load, the rated voltage is 230V~, and the rated current can be adjusted between 1A and 32A.

The EKEPCB2 controller is OCPP1.6J protocol with WIFI, Ethernet net communication, which can communicate with controller with a OCPP1.6J protocol backend, also we can support a RS485 communication for kWh meter.

The controller additional functions including: non-contact IC card connection module, residual current monitoring unit, DLB management, LCD display, kWh Meter, Electronic lock, external emergency stop pushbutton, etc. These function must be NOTED when ordering.

Technical Specification

Model	EKEPCB2-C/S
Mode	Mode 3 charging
Operating voltage	AC230V±10%, 50Hz
Output the PWM signal	Max: 32A, 1-32A adjustable
Basic function	<ul style="list-style-type: none"> • RCMU DC6mA leakage monitoring • Overtemperature protection • Overvoltage & undervoltage protection • Over current protection • Voltage, current, power for real time monitoring
Additional function	<ul style="list-style-type: none"> • Swipe RFID card/NFC start or stop charging function with an auxiliary device of RFID module and cards • LCD display function with an auxiliary device of LCD screen • Electronic lock function with a device electronic lock • DLB function with an auxiliary device of CT or kWh meter • Emergency stop function with an auxiliary device of pushbutton switch
Protocol (communication)	OCPP1.6J protocol, wifi & ethernet or add external 4G module communication
Output auxiliary voltage	DC12V/100mA, DC5V/100mA
Ambient temperature	-40°C ~ +50°C
Humidity	≤85%
Cooling method	Natural cooling
Installation method	PCB mounted

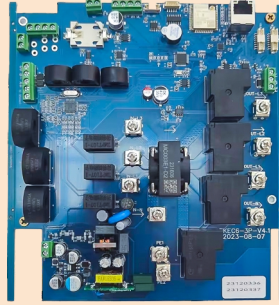

Brief Description

EKEPCB3 is using for AC EV Charging Station complies with IEC61851-1 or SAEJ1772 standard and PCB installation requirement.

The output the controller is using the relay switches on/off the load, the rated voltage is 230V~, and the rated current can be adjusted from 1A to 32A.

The EKEPCB3 controller is OCPP1.6J protocol with WIFI, Ethernet net communication, which can communicate with controller with a OCPP1.6J protocol backend, also we can support a RS485 communication for kWh meter.

The controller additional functions including: non-contact IC card connection module, residual current monitoring unit, DLB management, LCD display, kWh Meter, Electronic lock, external emergency stop pushbutton, etc. These function must be NOTED when ordering.

Technical Specification

Model	EKEPCB3-C/S
Mode	Mode 3 charging
Operating voltage	AC400V±10%, 50Hz
Output the PWM signal	Max: 32A, 1-32A adjustable
Basic function	<ul style="list-style-type: none"> • RCMU DC6mA leakage monitoring • Overtemperature protection • Overvoltage & undervoltage protection • Over current protection • Voltage, current, power for real time monitoring
Additional function	<ul style="list-style-type: none"> • Swipe RFID card/NFC start or stop charging function with an auxiliary device of RFID module and cards • LCD display function with an auxiliary device of LCD screen • Electronic lock function with a device electronic lock • DLB function with an auxiliary device of CT or kWh meter • Emergency stop function with an auxiliary device of pushbutton switch
Protocol (communication)	OCPP1.6J protocol, wifi & ethernet or add external 4G module communication
Output auxiliary voltage	DC12V/100mA, DC5V/100mA
Ambient temperature	-40°C ~ +50°C
Humidity	≤85%
Cooling method	Natural cooling
Installation method	PCB mounted



Overview

EKRCMU-1 is a residual current sensor with a highly integrated modular design, combining Type A RCD functionality with 6mA DC leakage detection, specially developed for charging pile leakage detection, Compliant with IEC 62955.

Its main function is to respond quickly when the charging pile detects residual current during operation, effectively preventing potential safety hazards caused by leakage, including but not limited to fire or electric shock accidents, thereby ensuring the safety and stability of the entire charging process, and is widely used in charging piles that meet mode 3 charging.

Features

- Dual Protection: Integrates Type A RCD functionality with 6mA DC leakage detection in a single unit.
- IEC 62955 Compliance: Meets the requirements of IEC 62955, the international standard for RCMU in EV charging stations.
- Enhanced DC Protection: Detects DC leakage currents as low as 6mA, crucial for modern EV charging safety.
- Connection Types: Suitable for both three-phase and single-phase connections.
- Fast Response Time: Interrupting Time according to IEC62752: 5.3.11 Table 2 and 3.
- Self-Monitoring: Continuous self-test functionality ensures reliable operation.
- Compact Design: Engineered to be compact for easy integration into EV charging stations.

Applications

- Mode 2 or Mode 3 AC charging stations
- Home and workplace EV chargers
- Combined AC/DC charging points
- Public charging infrastructure

Main Technical Data

Operating voltage	4.85~5.15V DC
Working current	10mA (typ.)
Power consumption	≤110mW
Voltage input/output, low level	0~0.6V DC
Voltage input/output, high level	4.2~5V DC
Leakage protection type	Type A + 6mA DC
Scope of application	Max. adaptable to 22kW single-phase or three-phase
Connection method	Pin strip 5-pos.
Ambient air temperature	-40°C~+85°C
Storage temperature	-40°C~+105°C
Humidity	≤95%

Leakage Parameters

Parameter	Symbol	Condition	Min.	Typ.	Max.
Primary rated current (A)	I_P	-	-	32	40
Measurement range (peak value) (mA)	$I_{\Delta N, \max}$	-	-300 ①	-	300
Frequency measurement range (kHz)	fBW	-	DC	-	1
Rated residual operating current 1(mA) DC	$I_{\Delta N1}$	-	3.0	4.8	6
Rated residual operating current 2 (mA) rms ②	$I_{\Delta N2}$	-	15	22	30
Response time (ms) ③	Tr	AC: $I_n=1 \cdot I_{\Delta N2}$	-	150	300
		AC: $I_n=2 \cdot I_{\Delta N2}$	-	90	150
		AC: $I_n=5 \cdot I_{\Delta N2}$	-	25	10
		DC: $I_n=1 \cdot I_{\Delta N1}$	-	300	10000
		DC: $I_n=10 \cdot I_{\Delta N1}$	-	90	300
		DC: $I_n=50 \cdot I_{\Delta N1}$	-	25	40

- ① The negative sign represents the direction of current flow.
- ② Hz=50Hz.
- ③ Interrupting Time according to IEC62752: 5.3.11 Table 2 and 3.

Application Circuit

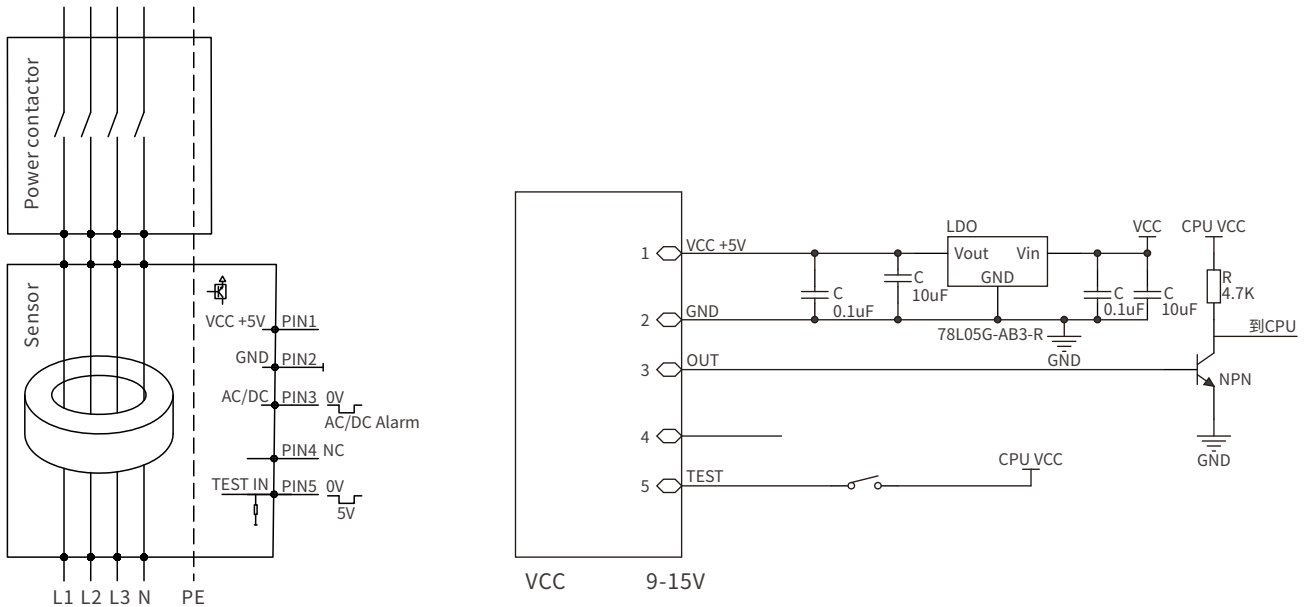

The detection module is sensitive to AC and DC currents and can be used for residual current detection of mode 2 or mode 3 charging equipment. The detection module detects AC and DC fault currents according to the IEC62752/IEC62955 standard requirements. In the case of an AC/DC fault current, PIN3 changes its state from a low level (GND) to a high-level state.

No.	Symbol	Description
PIN-1	VCC	<ul style="list-style-type: none"> Product power supply pin, standard supply voltage 5V DC. Input voltage range required is 4.8~5.2V DC.
PIN-2	GND	Power ground pin
PIN-3	TRIP	When it is detected that the residual current in the line exceeds the threshold (30mA or 6mA DC), the output level of PIN3 changes from low to high level state, and the driving current is 2mA.
PIN-4	/	NC-Float
PIN-5	TEST	<ul style="list-style-type: none"> Before starting charging, perform a simulation test on the product through this pin to verify whether the product function is normal. If this pin is connected to a high-level state, the functional test is activated (the activation voltage range must be 3V~12V).

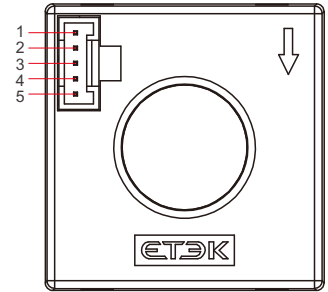

Power Up and Test Mode

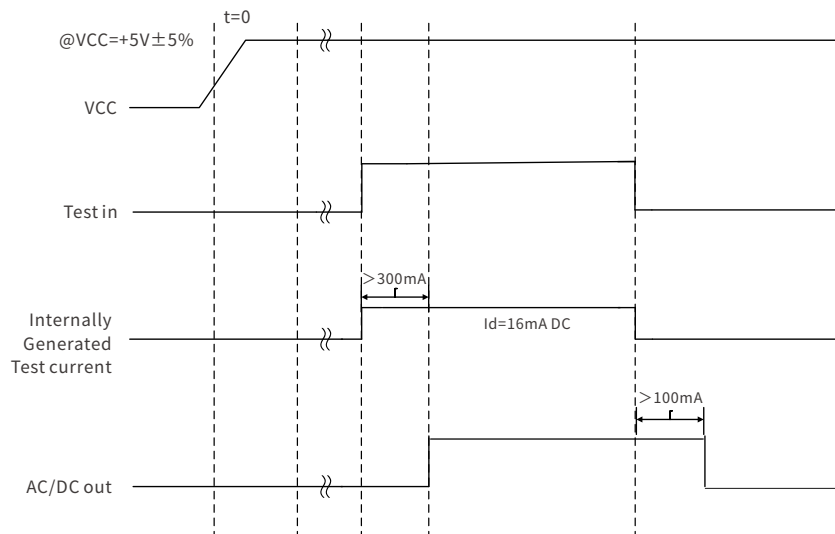

Dimension (mm)

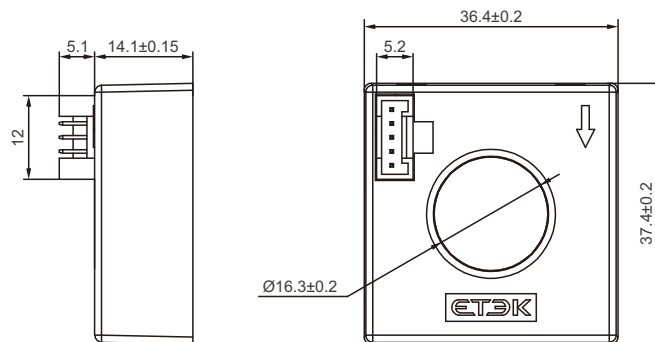



Impluse Electronic Lock Technical Parameters

Working power supply	DC12V/500mA
Max. working current	≤500mA
No-Load current	<50mA
Locking mechanism retention force	<80N
Locking mechanism breaking force	≥200N
Angle of rotation	≤90°
Response time	<50ms
Maximum power-on time	3.5s
Complete lock time	<300ms
Ambient temperature	-40°C-+80°C
Electrical life	≥30,000 cycles
Insulation resistance	500MΩ
Power-on action time	0.2s<t<1.0s
Pulse duty factor	35%
Protection degree	IP55
Manual unlocking pull	≤5N
Manual unlock life	≥30,000 cycles

Function Description

Red line (+12V)	Black line (0V)	Status	Feedback signal
+12V	0V	Lock condition	Switch connected
No-Load current	+12V	Unlock condition	Switch disconnected

Electrical Wiring Principle

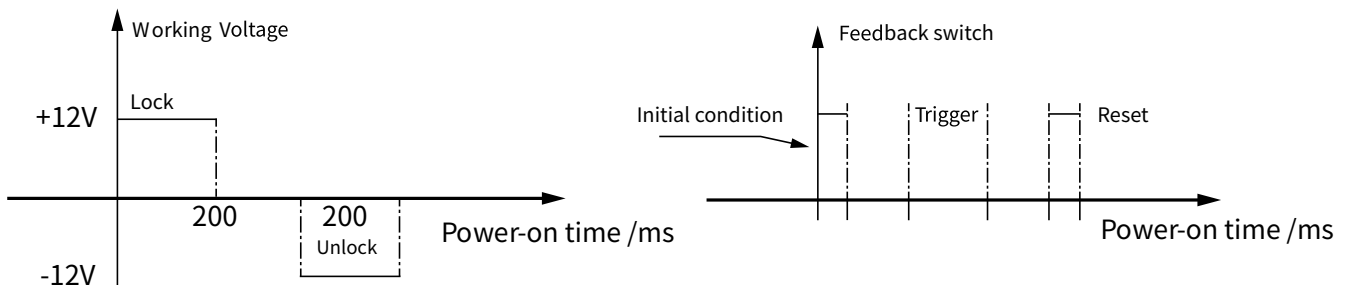
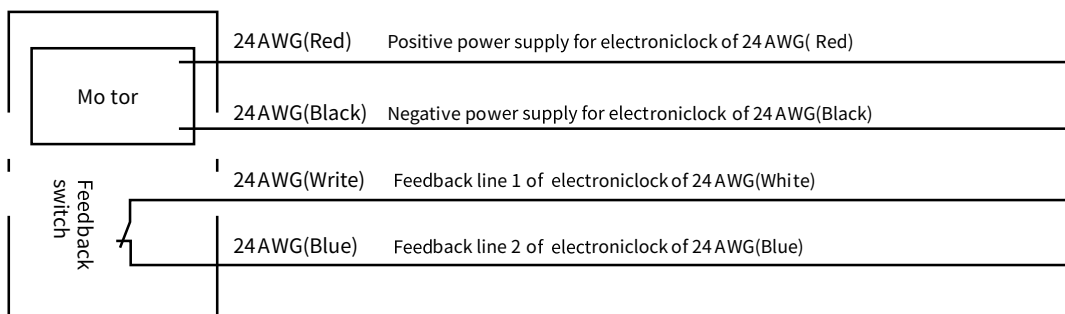

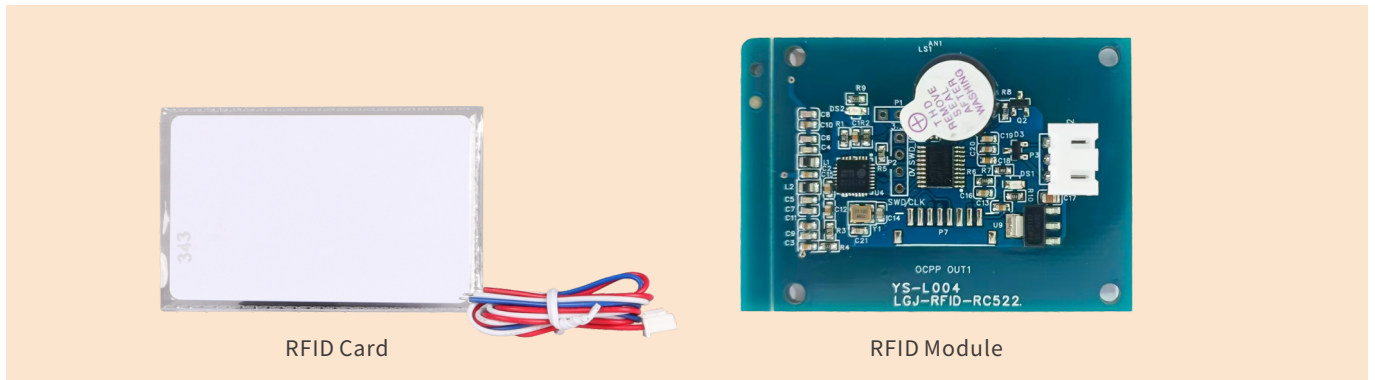

RFID

The charging station can be configured with contactless IC card swiping function, and charging can only be carried out through authorized IC card. If the IC card is lost, the internal dip switch can be used to set the IC card losing module. There are 2 IC cards which are authorized by the factory, unless specify that we can provide more IC cards.

LCD Display

The charging station can provide an analog input function, the input analog is AC0-1.0V, which is used to display the current working current. When the detected working current is greater than the set current value, the charging station will reduce the charging current to the set current value. Thereby ensuring the safe and reliable operation of the charging station.

Display Content



EKEC Series Charging Station		
Operation voltage:	220V	Set current: 32.0A Output Current: 32.0A
Electricity consumption:	15.8kWh	
Charging time:	1 h 01 min 01 s	
Operation status:	Charging	
Device status:	Normal	
Communication status :	Connecting	

The charging station with a LCD to display which can show the working status and charging related data, it is convenient and intuitive.



Technical Data

Rated operating voltage	$\leq 0.66\text{kV}$
Rated operating frequency	50-60Hz
Current ratio	100/5A
Rated input	100A
Measuring range	10%I _n ~120%I _n
Rated output	0.333V or 500mA
Accuracy	class 0.5
Ratio difference	$\leq \pm 1\%$
Phase difference	$\leq \pm 10\text{min}$
Dielectric strength	2.5kV/1mA/1min
Insulation resistance	500VAC/500 MΩ
Shell	ABS/UL94-V0
Operating temperature	-40°C~+70°C
Ambient humidity	$\leq 85\%$
Window hole size	24mm
Installation method	Cable tie fixation

Dimension (mm)

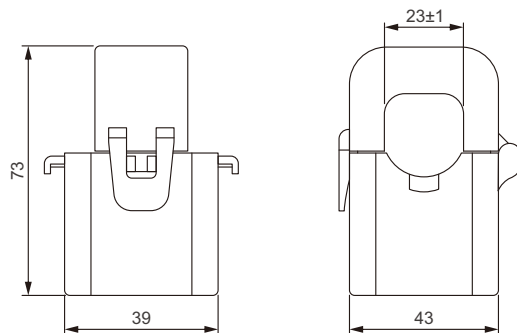



Main Parameter

Operation voltage	230V±10% 50Hz; 400V±10% 50Hz
Operation current	16A, 32A
Continuously using time	Continuously working 24h
Conductive terminal temperature rise	≤50K
Insulation resistance	≥500MΩ, DC500V
Withstand voltage	2500V/min
Contact resistance	≤0.3Ω
Mechanical life	5,0000 times or more
Insertion / pulling force during connection	45N~80N
Withstanding impact	Tolerable to 2 ton car rolling or 1m height drop without damage
Conductor material	Copper alloy + silver plating
Enclosure material	Thermoplastic flame retardant plastic, flame retardant grade UL94V-0
Ambient temperature	-40°C ~ +50°C
Humidity	<85%

Product Model Specifications

Model	Description
EKEP1-T2-16A	Single-phase 16A single-ended charging plug
EKEP1-T2-32A	Single-phase 32A single-ended charging plug
EKEP3-T2-16A	Three-phase 16A single-ended charging plug
EKEP3-T2-32A	Three-phase 32A single-ended charging plug

Model	Description
EKEP1-T2-D-16A	Single-phase 16A double-ended charging plug
EKEP1-T2-D-32A	Single-phase 32A double-ended charging plug
EKEP3-T2-D-16A	Three-phase 16A double-ended charging plug
EKEP3-T2-D-32A	Three-phase 32A double-ended charging plug

Dimension (mm)

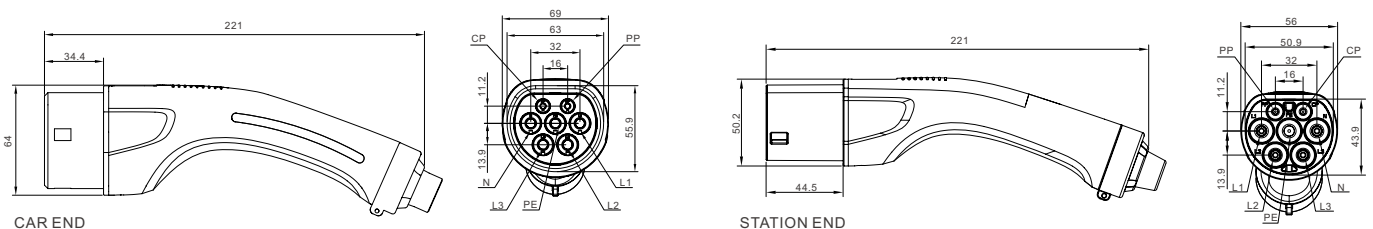



Dimension (mm)

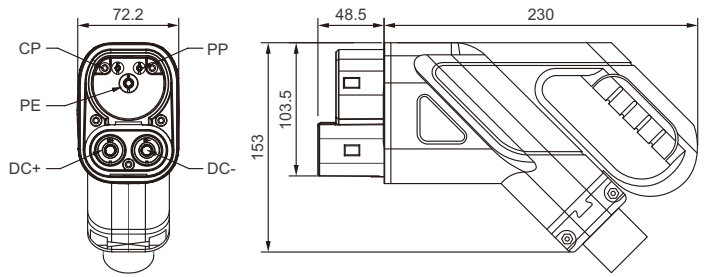

Overview

CCS type2 DC charging Plug, comply with the latest standards of IEC62196-12022 and IEC62196-32022, built-in temperature sensor, humanized man-machine design of product appearance, beautiful appearance, easy plugging and unplugging, comfortable grip.

Technical Data

Rated voltage	1000V DC
Rated current	80, 125, 150, 200, 250, 300A
Withstand voltage	DC+/DC-/PE \geq 3500V AC
Insulation resistance	Ambient temperature conditions \geq 500M Ω
Plug base material	PA66+25%GF
Plug color	Black (white color can customized)
Plug housing material	PC
Ambient temperature	-30 $^{\circ}$ C~+50 $^{\circ}$ C
IP degree	IP55 (In the connected state), IP67(In the plug area)
Flammability rating	Flame retardant UL94V-0
Insertion and unplugging force	F<100N
Mechanical life	Insertion and unplugging 10000 time
Cable color	Black (white can customized)
Cable length	5m (Cable length can customized)

Product Model Specifications and Corresponding Cable Specifications

Model	Current	Specifications (DC)	Power line temperature sensor	Cable specifications (mm ²)
EKEPDC-CCS2-080	80A	16mm ²	PT1000	3 \times 16+6 \times 0.75OD22.5 \pm 0.5
EKEPDC-CCS2-125	125A	35mm ²	PT1000	2 \times 35+25+6 \times 0.75OD26.5 \pm 0.6
EKEPDC-CCS2-150	150A	50mm ²	PT1000	2 \times 50+25+6 \times 0.75OD29.8 \pm 0.6
EKEPDC-CCS2-200	200A	70mm ²	PT1000	2 \times 70+25+6 \times 0.75OD34 \pm 0.7
EKEPDC-CCS2-250	250A	70mm ²	PT1000	2 \times 70+25+6 \times 0.75OD34 \pm 0.7
EKEPDC-CCS2-300	300A	2 \times 50mm ²	PT1000	4 \times 50+35+6 \times 1.5OD38.5 \pm 0.8

	Model	Description
	EKA-T2-T1	T2-T1 32A
	EKA-T1-T2	T1-T2 32A
	EKA-T1-GB/T	T1-GB/T 32A
	EKA-T2-GB/T	T2-GB/T single-phase 32A
	EKA-T2-GB/T-3	T2-GB/T three-phase 32A
	EKA-GB/T-T2	GB/T-T2 single-phase
	EKA-GB/T-T2-3	GB/T-T2 three-phase
	EKA-Tesla-T2	Tesla-T2 32A
	EKA-Tesla-T1	Tesla-T1 50A
	EKA-CCS2-GBT	CCS2-GBT 250A
	EKA-CCS2-CCS1	CCS2-CCS1

EKESL

EV Charging Socket - Type 2 Outlet



Technical

Charging standard	Type 2(IEC 62196) Shuttled Socket
Main material	PA66, Copper Alloys, Wires
Rated voltage	220-250V/380-450V
Rated current	16A/32A
Working temperature	-30°C-50°C
IP grade	IP54

Dimension (mm)

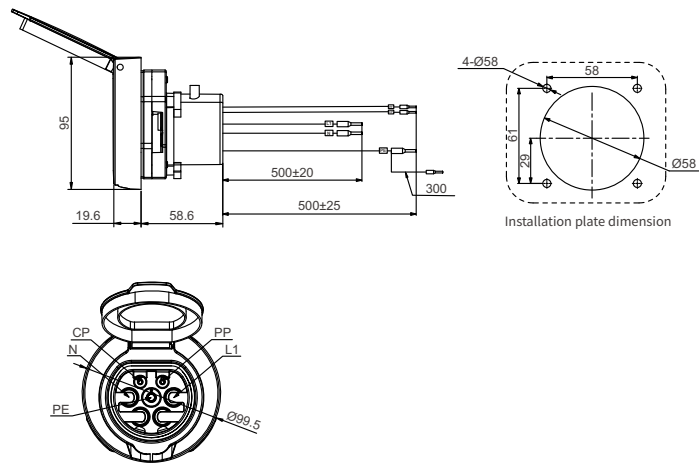

EKES

AC Charging Station Socket

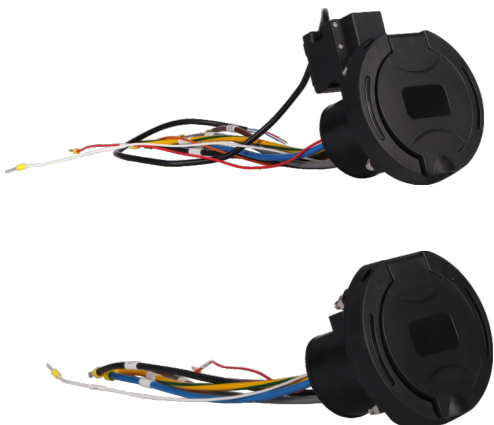



Technical

Charging standard	Type 2(IEC 62196) Socket
Main material	PA66, Copper Alloys, Wires
Rated voltage	220-250V/380-450V
Rated current	16A/32A
Working temperature	-30°C-50°C
IP grade	IP54

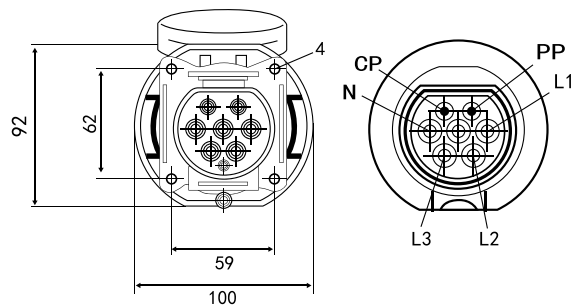
Dimension (mm)



EKEH1

EKEH1-GB-S, EKEH1-T2-S	EKEH1-GB-F, EKEH1-T2-F
	



EKEH2

EKEH2-GB	EKEH2-T2	EKEH2-T1
		
EKEH2-DCGB		EKEH2-CCS2
		

EKEH3

EKEH3-GB	EKEH3-T2	EKEH3-T1
		

EKEH4

EKEH4-GB	EKEH4-T2	EKEH4-T1
		



Overview

This product is AC V2L (Vehicle to load) discharge gun, support the use of two-way OBC new energy vehicle to load discharge, the vehicle battery pack DC power into AC output, voltage 220-240V, current up to 16A, general discharge power in 2kW to 6kW, through the AC discharge gun with the electric car to become a mobile power station function or camp power supply. Mode



Technical Data

Mechanical life	Insertion and unplugging above 10000 time
Connected force	F<100N
Operating temperature	-30°C ~ +50°C
Withstand voltage	2000V
Material	Housing thermoplastic, flame retardant grade UL94 V-0 Terminal: Copper alloy, silver plating
Insulation resistance	> 1000MΩ(DC500V)
Terminal temperature rise	<50K
Contact Resistance	0.5mΩ

Product Model Specifications

Model	Plug	Socket style	Voltage	Rated current	Cable
EKDP-F	Typ2 2 plug	Type F- Shuko socket	240V	16A	3meter, 3×2.5mm ²
EKDP-N	Typ2 2 plug	Type N- Brazil socket	240V	10A/20A	3meter, 3×2.5mm ²
EKDP-G	Typ2 2 plug	Type G-UK socket	240V	13A	3meter, 3×2.5mm ²
EKDP-A	Typ2 2 plug	Type A-China Socket	240V	10A/16A	3meter, 3×2.5mm ²

Portable Charger Bracket

	Model	Description
	EKEC2ZJ	Suit for all portable EV charger
	EKC2ZJ2	Suit for EKEC2 Style B

AC Charging Station Post

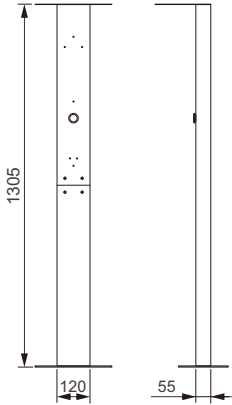
	Model	Description	Dimension (mm)
	EKLZ	Suit for all AC charging station	



Dimension(mm)

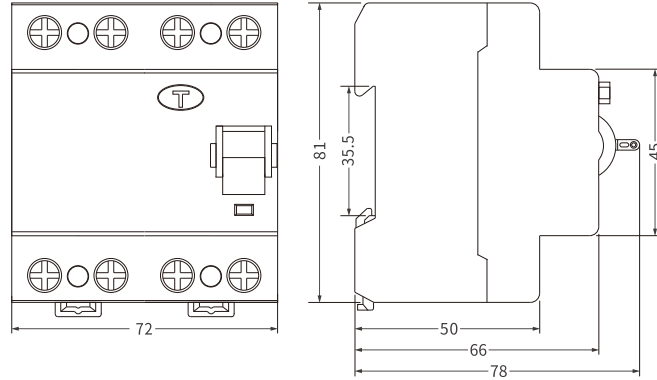

Technical Data

Standard	IEC/EN 61008-1, IEC 62423
Protection	Ground fault
Type of trip	Electro-magnetic
Residual current type	B
No. of poles	2P(1P+N), 4P(3P+N)
Rated voltage (Ue)	1P+N: 230/240V~, 3P+N: 400/415V~
Rated currents (In)	16,20,25,32,40,63A
Rated sensitivity currents (ΔIn)	30,100,300mA
Residual current off-time under (Δtn)	≤ 0.1s
Rated residual making and breaking capacity(IΔm)	500A(In≤50A), 10In(In>50A)
Rated frequency	50/60Hz
Rated conditional short-circuit current (Inc)	10kA
SCPD fuse	10000
Rated impulse withstand voltage (Uimp) (1.2/50μs)	4kV
Dielectric test voltage	2.5kV (50/60Hz, 1 min.)
Electrical life	2,000 Cycles
Mechanical life	4,000 Cycles
Contact position indicator	green OFF / red ON
Protection degree	IP20
Ambient temperature	-25°C to +40°C, Max.95% humidity
Terminal connection type	Cable/Pin-type busbar/Fork-type busbar
Max.terminal size for cable	25mm ²
Max.tightening torque	2.5N.m
Installation	Mounting on 35mm DIN rail
Incoming method	Bi-Directional



Dimension(mm)

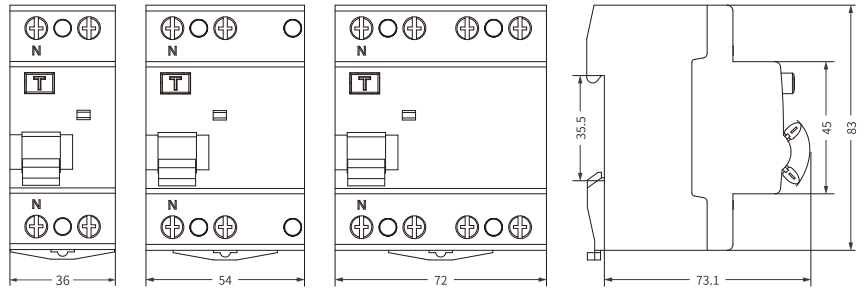

Technical Data

Standard	IEC 61008-1, IEC 62423
Protection	Ground fault
Type of trip	Electro-magnetic
Residual current type	B
No. of poles	2P(1P+N), 4P(3P+N), N Pole on left
Insulation voltage (Ui)	500V
Rated voltage (Ue)	2P(1P+N):110/230/240V~, 4P(3P+N):240/400/415V~
Rated currents (In)	16,25,32,40,63,80,100A
Rated sensitivity currents (IΔn)	30,100,300mA
Residual current off-time under (IΔn)	≤ 0.1s
Rated residual making and breaking capacity (IΔm)	500A(IΔn ≤ 50A), 10IΔn(IΔn > 50A)
Rated frequency	50/60Hz
Rated conditional short-circuit current (Inc)	10kA
SCPD fuse	10000
Rated impulse withstand voltage (Uimp) (1.2/50μs)	4kV
Dielectric test voltage	2.5kV (50/60Hz, 1 min.)
Electrical life	2,000 Cycles
Mechanical life	4,000 Cycles
Contact position indicator	green OFF / red ON
Ground fault indicator	White: Normal, Red: Leakage fault
Protection degree	IP20
Ambient temperature	-25°C to +40°C, Max.95% humidity
Terminal connection type	Cable/Pin-type busbar/Fork-type busbar
Max.terminal size for cable	35mm ²
Max.tightening torque	2.5N.m
Installation	Mounting on 35mm DIN rail
Incoming method	Bi-Directional



Dimension(mm)

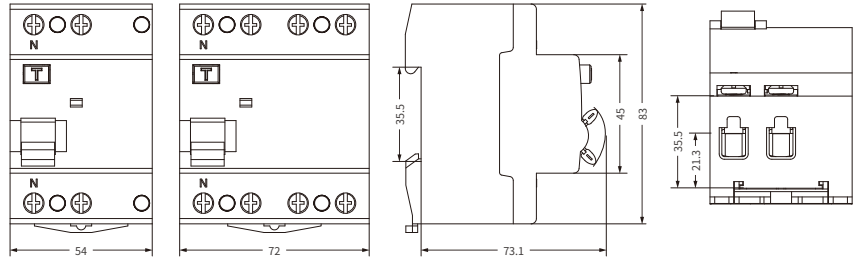

Technical Data

Standard	IEC 61008-1, IEC 62955
Protection	Ground fault
Type of trip	Electro-magnetic
Residual current type	A
Classification of RDC-DD	RDC-PD
No. of poles	2P(1P+N), 4P(3P+N) , N Pole on left
Insulation voltage (Ui)	500V
Rated voltage (Ue)	2P: 240V~, 4P: 415V~
Rated currents (In)	16,25,32,40,63A
Rated sensitivity currents (I Δ n)	30mA
Rated residual operating current (I Δ dc)	6mA
Residual current off-time under (I Δ n)	$\leq 0.1s$
Rated residual making and breaking capacity (I Δ m)	500A(I Δ n \leq 50A), 10I Δ n(I Δ n>50A)
Rated frequency	50/60Hz
Rated conditional short-circuit current (Inc)	10kA
SCPD fuse	10000
Rated impulse withstand voltage (Uimp) (1.2/50 μ s)	4kV
Dielectric test voltage	2.5kV (50/60Hz, 1 min.)
Electrical life	2,000 Cycles
Mechanical life	4,000 Cycles
Contact position indicator	green OFF / red ON
Ground fault indicator	White: Normal, Red: Leakage fault
Protection degree	IP20
Ambient temperature	-25°C to +55°C, Max.95% humidity
Terminal connection type	Cable/Pin-type busbar/Fork-type busbar
Max.terminal size for cable	35mm ²
Max.tightening torque	2.5N.m
Installation	Mounting on 35mm DIN rail
Incoming method	Bi-Directional

Tripping Sensitivity

- 30mA: This is the most commonly used protection level in homes and commercial buildings, and is suitable for socket protection in general residential environments, offices and commercial places.
- 100mA: Usually used in situations where personal protection requirements are not as strict as 30mA, or for equipment protection, such as air conditioning systems, industrial equipment, etc.
- 300mA: Mainly used for fire protection, such as distribution boards and general protection of large electrical equipment.

RCD Type

A		Able to detect alternating current (AC) leakage current and pulsed DC leakage current. It is suitable for environments where DC leakage may occur, including places where modern electrical equipment such as inverters, UPS (uninterruptible power supply systems), and LED lighting are used.
B		Able to detect alternating current (AC), pulsed DC leakage current, and smooth DC leakage current. Type B RCDs provide the most comprehensive protection and can detect all types of leakage currents. Suitable for special applications, such as electric vehicle charging stations, photovoltaic systems, medical equipment, etc., where a large amount of DC component leakage current may be generated.

Tripping Time

Instantaneous	Two types of leakage protectors, AC and A, are usually designed to quickly disconnect circuits ($\leq 300\text{ms}$) to protect people from electric shock.
Short time delay	Designed for use in situations where rapid power outage is required to protect equipment. They have shorter trip times (10-300ms) than Type AC and Type A RCDs to minimize damage to the equipment.
Selective	Designed to allow downstream RCDs to trip before upstream RCDs, thereby achieving precise isolation of faulty sections. The S-type RCD is designed with a longer tripping time (130-500ms) to coordinate with other RCDs in the power distribution system to avoid unnecessary power outages.

Breaking Time of Residual Current

$I_n(\text{A})$	$I_{\Delta n}(\text{A})$	Max. breaking time			
		$I_{\Delta n}$	$2I_{\Delta n}$	$5I_{\Delta n}$	5,10,20,50,100,200,500A
16,20,25,32,40,63,80,100	0.03, 0.1, 0.3	0.1s	0.08s	0.04s	0.04s

Wiring The suitable conductors should be used for connection, see table below for relative parameters.

Rated current I_n (A)	Cross section area s (mm^2)	Tightening torque (N.m)
16	2.5	2.5
20	2.5	2.5
25	4	2.5
32	6	2.5
40	10	2.5
63	16	2.5
80	25	2.5
100	35	2.5

Circuit Diagram

• EKL1-63B(H)

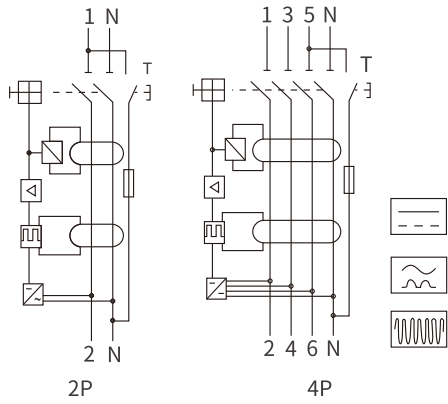

• EKL6-100B

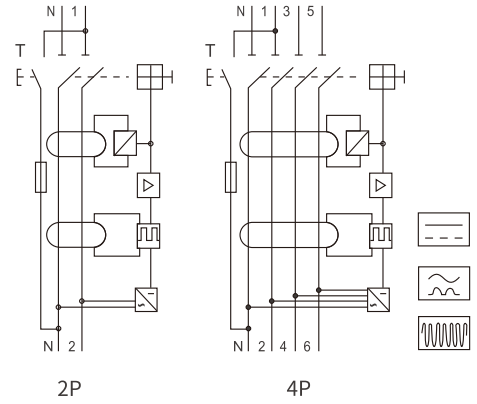

• EKL6-63EV

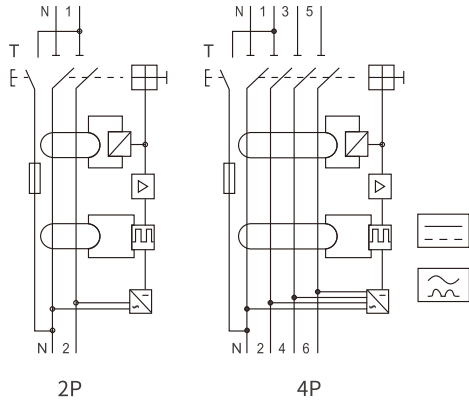

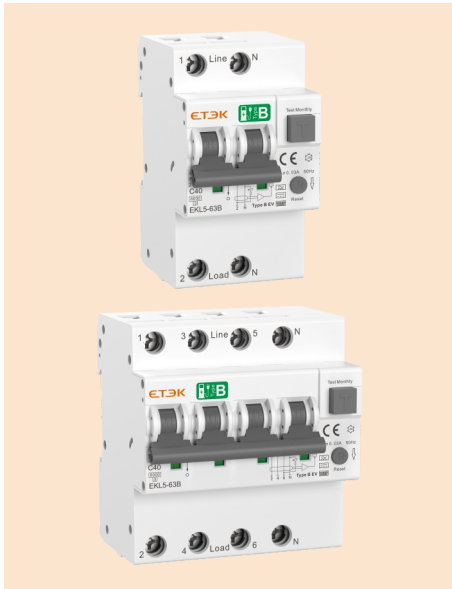

Dimension(mm)

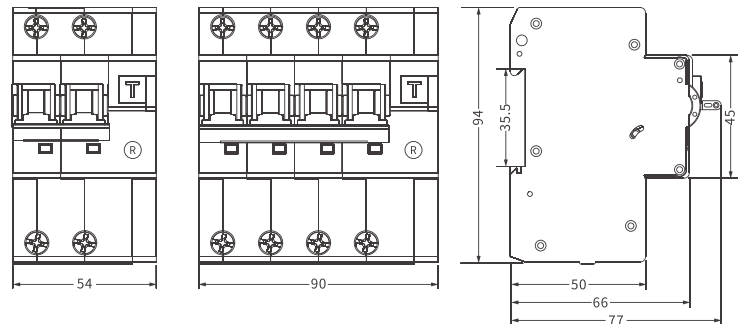

Technical Data

Standard	IEC/EN 61009-1, IEC/EN 62423
Protection	Ground fault, Overcurrent and short circuit
Type of trip	Ground fault : Electronic Overload and short circuit :Thermo-magnetic
Residual current type	B
No. of poles	1P+N 3module, 3P+N 5module (with switched neutral)
Rated voltage (Ue)	1P+N:230/240V~, 3P+N:400/415V~
Rated currents (In)	6,10,16,20,25,32,40,50,63A
Rated sensitivity currents (IΔn)	30,100,300mA
Residual current off-time under (IΔn)	≤ 0.1s
Rated residual making and breaking capacity (IΔm)	500A(In≤50A), 10In(In>50A)
Rated frequency	50/60Hz
Rated breaking capacity	10kA
Energy limiting class	3
Rated impulse withstand voltage (Uimp) (1.2/50μs)	4kV
Dielectric test voltage	2kV (50/60Hz, 1 min.)
Thermal tripping characteristics	1.13 x In No tripping within an hour; 1.45 x In Tripping within an hour
Instantaneous tripping characteristics	B:(3-5) x In, C:(5-10) x In, D:(10-20) x In
Electrical life	4,000 Cycles
Mechanical life	10,000 Cycles
Contact position indicator	green OFF / red ON
Protection degree	IP20
Ambient temperature	-25°C to +55°C, Max.95% humidity
Terminal connection type	Cable/Pin-type busbar/Fork-type busbar
Max. terminal size for cable	25mm ²
Max. tightening torque	2.5N.m
Installation	Mounting on 35mm DIN rail
Incoming method	From top



Dimension(mm)

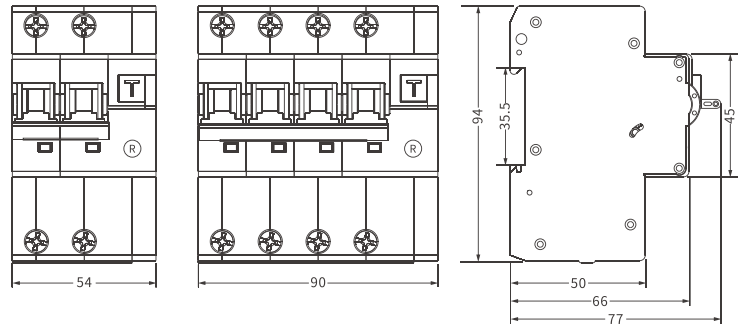

Technical Data

Standard	IEC/EN61009-1 ,IEC/EN62423
Protection	Ground fault, Overcurrent and short circuit
Type of trip	Ground fault : Electronic Overload and short circuit :Thermo-magnetic
Residual current type	A
No. of poles	1P+N 3module, 3P+N 5module, N line with disconnected
Rated voltage (Ue)	1P+N:230/240V~, 3P+N:400/415V~
Rated currents (In)	16,20,25,32,40,50,63A
Rated sensitivity currents (IΔn)	30mA
Rated sensitivity currents (IΔdc)	6mA
Residual current off-time under (IΔn)	≤ 0.1s
Rated residual making and breaking capacity (IΔm)	500A(In≤50A), 10In(In>50A)
Rated frequency	50/60Hz
Rated breaking capacity	10kA
Energy limiting class	3
Rated impulse withstand voltage (Uimp) (1.2/50μs)	4kV
Dielectric test voltage	2kV
Thermal tripping characteristics	1.13 x In No tripping within an hour; 1.45 x In Tripping within an hour
Instantaneous tripping characteristics	B:(3-5) x In, C:(5-10) x In
Electrical life	4,000 Cycles
Mechanical life	10,000 Cycles
Contact position indicator	green OFF / red ON
Protection degree	IP20
Ambient temperature	-25°C to +40°C, Max.95% humidity
Terminal connection type	Cable/Pin-type busbar
Max. terminal size for cable	25mm ²
Max. tightening torque	2.5N.m
Installation	Mounting on 35mm DIN rail
Incoming method	From top

Tripping Characteristic

Data acc. to IEC/EN 60898-1										
Curve	Rated current	Thermal release				Ambient temperature	Magnetic release			Ambient temperature
		Non-trip	Trip	Non-trip time	Trip time		Hold current	Trip current	Trip time	
B	6-63A	1.13In		≤1h		30°C+5°C	3In		≥0.1	Normal temperature
			1.45In		<1h		5In		<0.1	
C	6-63A	1.13In		≤1h			5In		≥0.1	
			1.45In		<1h		10In		<0.1	
D	6-63A	1.13In		≤1h			10In		≥0.1	
			1.45In		<1h		20In		<0.1	

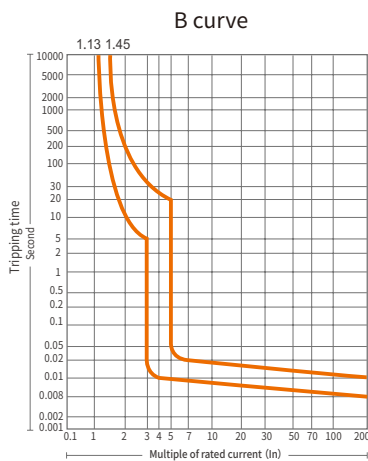

Universal use
- socket outlet, lighting device

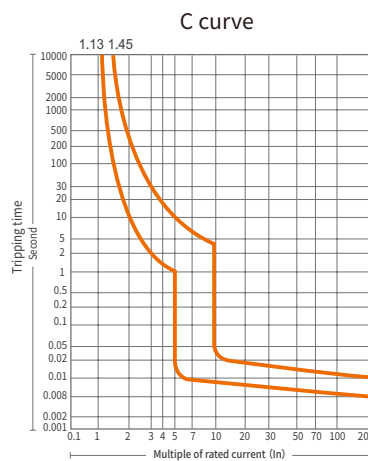

Resistive & inductive loads with low inrush current
- lamp, high starting current motor

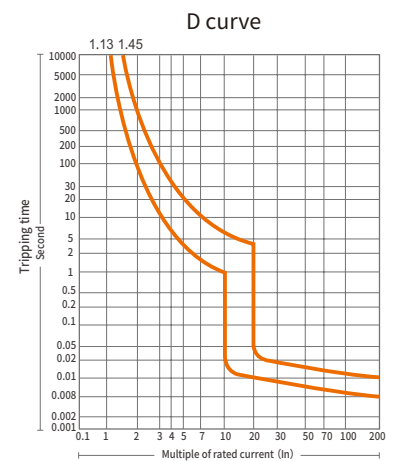

Loads with high inrush current
- transformer, solenoid valve, 2 pole motor

Temperature Derating Table

Rated current (A)	Correction factor for ambient temperature											
	-40°C	-30°C	-20°C	-10°C	0°C	10°C	20°C	30°C	40°C	50°C	60°C	70°C
6	8	7.7	7.5	7.2	6.9	6.6	6.3	6	5.7	5.3	4.9	4.5
10	13.3	12.9	12.5	12	11.5	11.1	10.5	10	9.4	8.8	8.2	7.5
16	21.3	20.7	20	19.2	18.5	17.7	16.9	16	15.1	14.1	13.1	11.9
20	26.7	25.8	24.9	24	23.1	22.1	21.1	20	18.9	17.6	16.3	14.9
25	33.3	32.3	31.2	30	28.9	27.6	26.4	25	23.6	22	20.4	18.6
32	42.7	41.3	39.9	38.5	37	35.4	33.7	32	30.2	28.2	26.1	23.9
40	53.3	51.6	49.9	48.1	46.2	44.2	42.2	40	37.7	35.3	32.7	29.8
50	66.7	64.5	62.4	60.1	57.7	55.3	52.7	50	47.1	44.1	40.8	37.3
63	84	81.3	78.6	75.7	72.7	69.6	66.4	63	59.4	55.6	51.4	47

Tripping Sensitivity

- 30mA: This is the most commonly used protection level in homes and commercial buildings, and is suitable for socket protection in general residential environments, offices and commercial places.
- 100mA: Usually used in situations where personal protection requirements are not as strict as 30mA, or for equipment protection, such as air conditioning systems, industrial equipment, etc.
- 300mA: Mainly used for fire protection, such as distribution boards and general protection of large electrical equipment.

RCD Type

A 

Able to detect alternating current (AC) leakage current and pulsed DC leakage current. It is suitable for environments where DC leakage may occur, including places where modern electrical equipment such as inverters, UPS (uninterruptible power supply systems), and LED lighting are used.

B 

Able to detect alternating current (AC), pulsed DC leakage current, and smooth DC leakage current. Type B RCDs provide the most comprehensive protection and can detect all types of leakage currents. Suitable for special applications, such as electric vehicle charging stations, photovoltaic systems, medical equipment, etc., where a large amount of DC component leakage current may be generated.

Circuit Diagram

• EKL5-63B

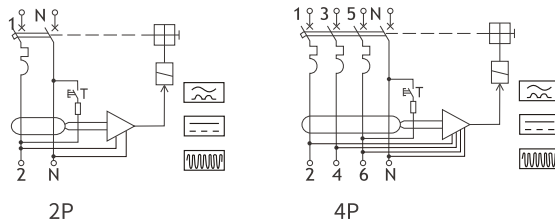

• EKL5-63EV

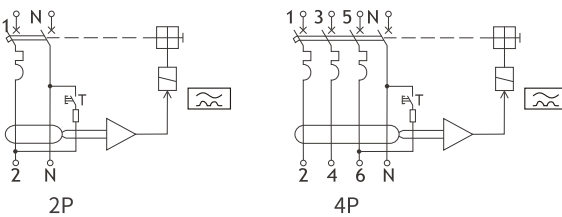



Technical Data





Standard	IEC61095
Poles	1P, 2P, 3P, 4P
Method of control	Automatic
Rated operational voltage Ue (V)	AC250V (1P, 2P), AC400V (3P, 4P)
Number of main contacts	1P: 1NO,1NC; 2P: 1NO+1NC, 2NO2NC 3P: 3NO, 3NC; 4P: 2NO+2NC, 3NO+1NC, 4NO, 4NC
Rated impulse withstand voltage Uimp (V)	4kV
Rated operational currents Ie (A)	16-125A (AC-7a), 6-50A (AC-7b)
Rated frequency (Hz)	50/60Hz
Utilization category	AC-7a/AC-7b
Rated control supply voltage Us	AC24V; AC110V; AC220-240V
Mechanical life (times)	10 × 10 ⁶
Electrical life (times)	10 × 10 ⁵

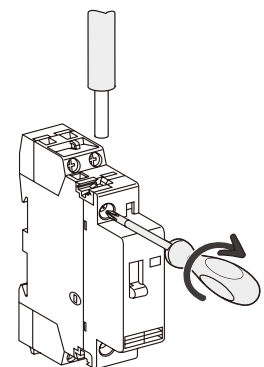



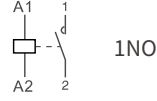
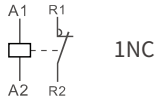
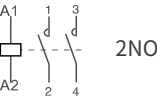
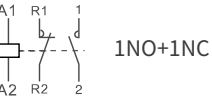
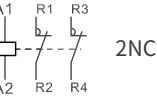

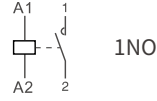
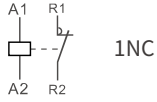
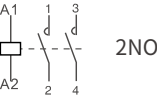
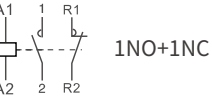
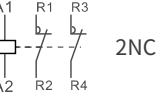

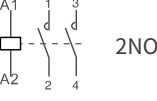
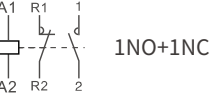
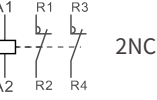

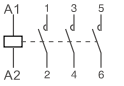
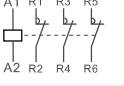

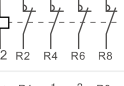
Connection Parameter

Type	Rated Current	Length tripping	Circuit	Tightening torque	Copper cables		
					Rigid	Flexible or Ferrule	
EKMF	PZ1: 4mm	16-100A	9mm	Control	0.8N.m	1.5~2.5mm ² 2x1.5mm ²	1.5~2.5mm ² 2x2.5mm ²
		16-25A	9mm	Power	0.8N.m	1.5~6mm ²	1~4mm ²
	PZ2: 6mm	40-63A	14mm	Power	3.5N.m	6~25mm ²	6~16mm ²
		100A	14mm	Power	3.5N.m	6x3.5mm ²	6~35mm ²

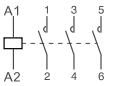
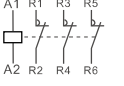
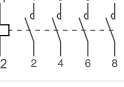

Automatic Type Product Selection Form

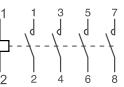
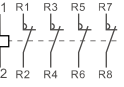
Modules	Poles	Contactor Model	Rated Current		Coil voltage VAC	Circuit Diagram	
			AC-1, AC-7a	AC-3, AC-7b			
 <p>1 Modules</p>	1P	EKMF-1610	16A	6A	24 110 230	 1NO	
		EKMF-2010	20A	7A		 1NC	
		EKMF-2510	25A	9A			
		EKMF-1601	16A	6A			
		EKMF-2001	20A	7A			
		EKMF-2501	25A	9A			
	2P	EKMF-1620	16A	6A			 2NO
		EKMF-2020	20A	7A			
		EKMF-2520	25A	9A			
		EKMF-1611	16A	6A		 1NO+1NC	
		EKMF-2011	20A	7A			
		EKMF-2511	25A	9A			
EKMF-1602	16A	6A	 2NC				
EKMF-2002	20A	7A					
EKMF-2502	25A	9A					
 <p>2 Modules</p>	1P	EKMF-3210		32A	12A	24 110 230	 1NO
		EKMF-4010		40A	18A		 1NC
		EKMF-6310		63A	25A		
		EKMF-3201	32A	12A			
		EKMF-4001	40A	18A			
		EKMF-6301	63A	25A			
	2P	EKMF-3220	32A	12A	 2NO		
		EKMF-4020	40A	18A			
		EKMF-6320	63A	25A			
		EKMF-3211	32A	12A			 1NO+1NC
		EKMF-4011	40A	18A			
		EKMF-6311	63A	25A			
EKMF-3202	32A	12A	 2NC				
EKMF-4002	40A	18A					
EKMF-6302	63A	25A					
 <p>3 Modules</p>	2P	EKMF-8020		80A	32A	24 110 230	 2NO
		EKMF-10020		100A	40A		
		EKMF-12520		125A	50A		 1NO+1NC
		EKMF-8011	80A	32A			
		EKMF-10011	100A	40A			
		EKMF-12511	125A	50A			
		EKMF-8002	80A	32A	 2NC		
		EKMF-10002	100A	40A			
EKMF-12502	125A	50A					

Modules	Poles	Contactor Model	Rated Current		Coil voltage VAC	Circuit Diagram
			AC-1, AC-7a	AC-3, AC-7b		
 <p>2 Modules</p>	3P	EKMF-1630	16A	6A	24 110 230 380	 3NO
		EKMF-2030	20A	7A		 3NC
		EKMF-2530	25A	9A		
		EKMF-1603	16A	6A		 4NO
		EKMF-2003	20A	7A		
		EKMF-2503	25A	9A		
	EKMF-1640	16A	6A	 4NC		
	EKMF-2040	20A	7A			
	EKMF-2540	25A	9A			
	EKMF-1604	16A	6A			 2NO+2NC
	EKMF-2004	20A	7A			
	EKMF-2504	25A	9A			 3NO+1NC
	EKMF-1622	16A	6A			
	EKMF-2022	20A	7A			
EKMF-2522	25A	9A				
EKMF-1631	16A	6A				
EKMF-2031	20A	7A				
EKMF-2531	25A	9A				
 <p>3 Modules</p>	3P	EKMF-3230	32A	12A	24 110 230 380	 3NO
		EKMF-4030	40A	18A		 3NC
		EKMF-6330	63A	25A		
		EKMF-3203	32A	12A		 4NO
		EKMF-4003	40A	18A		
		EKMF-6303	63A	25A		
	EKMF-3240	32A	12A	 4NC		
	EKMF-4040	40A	18A			
	EKMF-6340	63A	25A			
	EKMF-3204	32A	12A			 2NO+2NC
	EKMF-4004	40A	18A			
	EKMF-6304	63A	25A			 3NO+1NC
	EKMF-3222	32A	12A			
	EKMF-4022	40A	18A			
EKMF-6322	63A	25A				
EKMF-3231	32A	12A				
EKMF-4031	40A	18A				
EKMF-6331	63A	25A				
 <p>6 Modules</p>	4P	EKMF-8040	80A	32A	24 110 230 380	 4NO
		EKMF-10040	100A	40A		 4NC
		EKMF-12540	125A	50A		
		EKMF-8004	80A	32A		 2NO+2NC
		EKMF-10004	100A	40A		
		EKMF-12504	125A	50A		
		EKMF-8022	80A	32A		
		EKMF-10022	100A	40A		
		EKMF-12522	125A	50A		
		EKMF-8031	80A	32A		
EKMF-10031	100A	40A				
EKMF-12531	125A	50A				

Consumption

Poles	Rated Current		Control voltage (VAC)	Power consumption		Max. power
	AC-7a	AC-7b		Holding	Inrush	
1P	16A	6A	230	2.8VA	11.5VA	1.2W
	20A	7A	230	2.8VA	11.5VA	1.2W
	25A	9A	230	2.8VA	11.5VA	1.2W
2P	16A	6A	230	2.8VA	11.5VA	1.2W
	20A	7A	230	2.8VA	11.5VA	1.2W
	25A	9A	230	2.8VA	11.5VA	1.2W
	32A	12A	230	4.1VA	31VA	1.6W
	40A	18A	230	4.1VA	31VA	1.6W
	63A	25A	230	4.1VA	31VA	1.6W
	100A	-	230	4.1VA	31VA	2.1W
3P	16A	6A	230	4.1VA	31VA	1.6W
	20A	7A	230	4.1VA	31VA	1.6W
	25A	9A	230	4.1VA	31VA	1.6W
	32A	12A	230	7VA	48VA	2.1W
	40A	18A	230	7VA	48VA	2.1W
	63A	25A	230	7VA	48VA	2.1W
	100A	-	230	13VA	106VA	4.2W
4P	16A	6A	230	4.1VA	31VA	1.6W
	20A	7A	230	4.1VA	31VA	1.6W
	25A	9A	230	4.1VA	31VA	1.6W
	32A	12A	230	7VA	48VA	2.1W
	40A	18A	230	7VA	48VA	2.1W
	63A	25A	230	7VA	48VA	2.1W
	100A	-	230	13VA	106VA	4.2W

Dimension(mm)

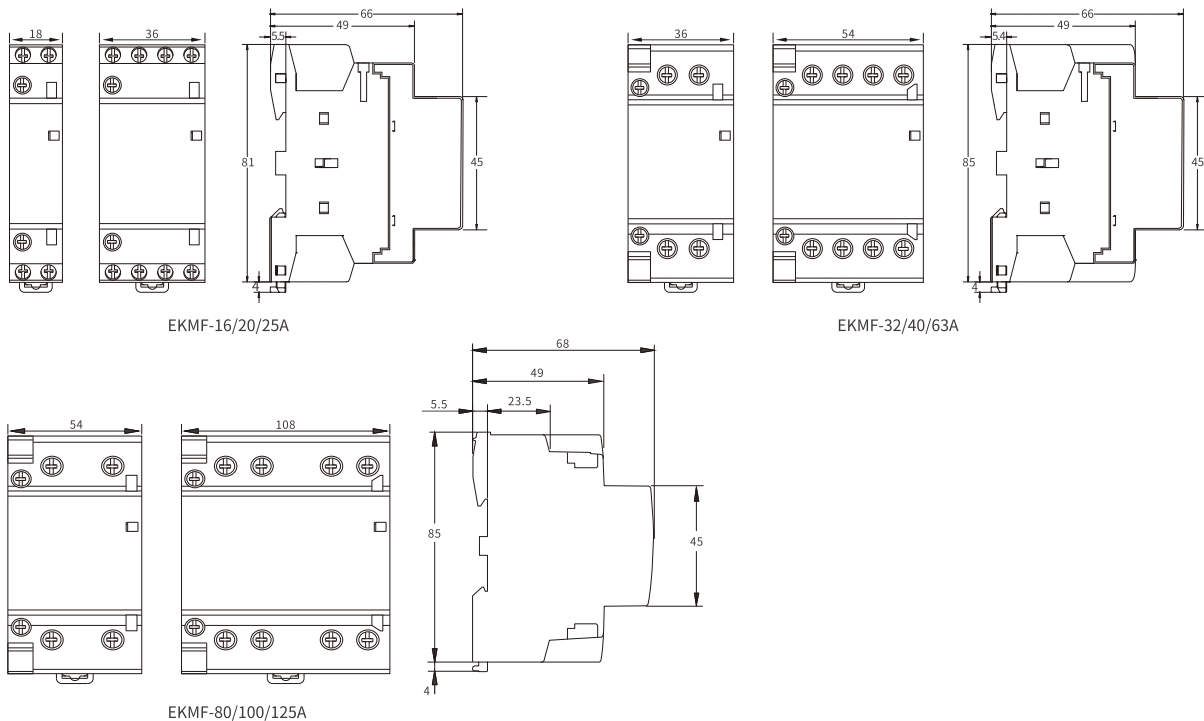



Technical Data

Voltage	Reference voltage	AC 230V
	Reference frequency	50Hz
	Power consumption	<10VA
Current	Reference current	0.5-10(80)A
	Consumption	<4VA
Accuracy of measuring		Class B
Range of measuring		000000.00~99999999kWh
Clock accuracy		Error≤0.5s/d
Active pulse	Pulse width	80±20ms
	Pulse constant	1000imp/kWh
Communication	Interface	RS485(A+, B-)
	Connection mode	Shielded twisted pair conductors
	Protocol	MODBUS-RTU
Max. tightening torque		<1.8Nm
Work temperature		-25°C to +55°C
Storage Temperature		-40°C to +70°C
Relative humidity		≤95%(No condensation)
Altitude		<2000m

Dimension(mm)

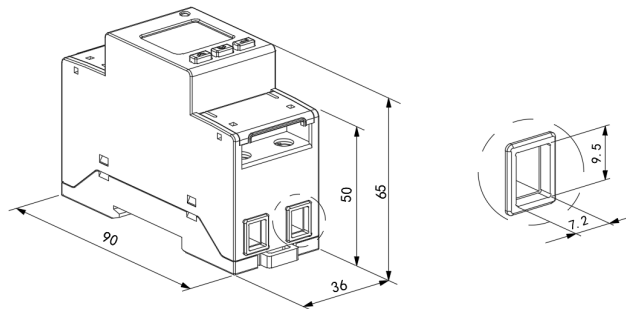



Technical Data

Specification		3 phase 3 wires	3 phase 4 wires
Voltage	Reference voltage	3×100V, 3×400V	3×57.7/100V, 3×230/400V
	Voltage range	3×100V~3×450V	3×57.7/100V~3×260/450V
	Consumption	<10VA(Single phase)	
	Impedance	>2MΩ	
	Accuracy class	Error±0.2%	
Current	Input current	0.01-1(6)A (Secondary access model) 0.5-10(80)A(Direct access model)	
	Consumption	<1VA Single phase rated current	
	Accuracy class	Error±0.2%	
Power	Active, reactive, apparent power, error±0.5%		
Frequency	45~65Hz, Error±0.2%		
Active Energy Class(kWh)	C(kWh)		
Clock	≤0.5s/d		
Energy pulse output	1 active photocoupler output		
Width of pulse	80±20ms		
Pulse constant	10000imp/kWh		
Interface and communication protocol	RS485: Modbus RTU		
Range of communication address	Modbus RTU:1~ 247		
Baud rate	1200bps~38400bps		
working temperature	-25°C to +55°C		
Relative humidity	≤95%(No condensation)		

Dimension(mm)

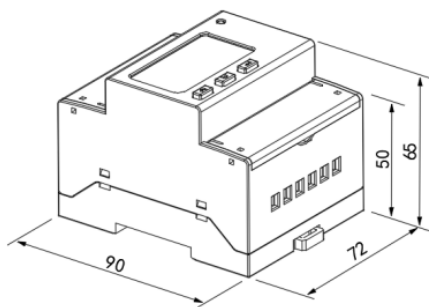

connect via CT

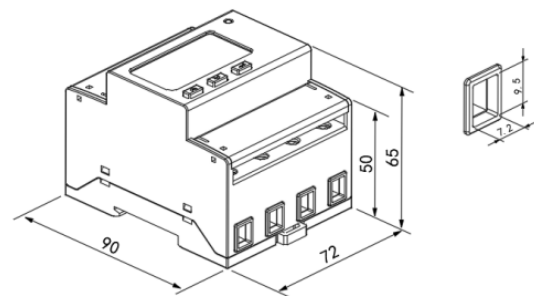

direct connect

 The product data referred to in the company shall be subject to material object. Subject to change without notice.
The company has the final right to interpret.

 Green paper printing.

ETEC

ZHEJIANG ETEK ELECTRICAL TECHNOLOGY CO..LTD.

No.288 Wei 17th Road, Economic Development Zone, Yueqing City, Zhejiang China.

Tel: 0086-577-62718777 0086-577-62780116

Email: info@etek-china.com

Web: www.etek-china.com



WUHU ETEK ELECTRIC CO..LTD.

No.770 Wutun Fast Road, Anhui Xinwu Economic Development Zone, Wanzhi District,
Wuhu City, Anhui Province, P.R.China

Tel: 0086-553-8511789

Email: sales@etek-electric.com

Web: www.etek-electric.com

