



Overview

EKRCMU-1 is a residual current sensor with a highly integrated modular design, combining Type A RCD functionality with 6mA DC leakage detection, specially developed for charging pile leakage detection, Compliant with IEC 62955.

Its main function is to respond quickly when the charging pile detects residual current during operation, effectively preventing potential safety hazards caused by leakage, including but not limited to fire or electric shock accidents, thereby ensuring the safety and stability of the entire charging process, and is widely used in charging piles that meet mode 3 charging.

Features

- Dual Protection: Integrates Type A RCD functionality with 6mA DC leakage detection in a single unit.
- IEC 62955 Compliance: Meets the requirements of IEC 62955, the international standard for RCMU in EV charging stations.
- Enhanced DC Protection: Detects DC leakage currents as low as 6mA, crucial for modern EV charging safety.
- Connection Types: Suitable for both three-phase and single-phase connections.
- Fast Response Time: Interrupting Time according to IEC62752: 5.3.11 Table 2 and 3.
- Self-Monitoring: Continuous self-test functionality ensures reliable operation.
- Compact Design: Engineered to be compact for easy integration into EV charging stations.

Applications

- Mode 2 or Mode 3 AC charging stations
- Combined AC/DC charging points
- Home and workplace EV chargers
- Public charging infrastructure

Main Technical Data

| | |
|----------------------------------|----------------------------------------------------|
| Operating voltage | 4.85~5.15V DC |
| Working current | 10mA (typ.) |
| Power consumption | ≤110mW |
| Voltage input/output, low level | 0~0.6V DC |
| Voltage input/output, high level | 4.2~5V DC |
| Leakage protection type | Type A + 6mA DC |
| Scope of application | Max. adaptable to 22kW single-phase or three-phase |
| Connection method | Pin strip 5-pos. |
| Ambient air temperature | -40°C~+85°C |
| Storage temperature | -40°C~+105°C |
| Humidity | ≤95% |

Leakage Parameters

| Parameter | Symbol | Condition | Min. | Typ. | Max. |
|-----------------------------------------------|----------------------|----------------------------------|--------|------|-------|
| Primary rated current (A) | I_P | - | - | 32 | 40 |
| Measurement range (peak value) (mA) | $I_{\Delta N, \max}$ | - | -300 ① | - | 300 |
| Frequency measurement range (kHz) | fBW | - | DC | - | 1 |
| Rated residual operating current 1(mA) DC | $I_{\Delta N1}$ | - | 3.0 | 4.8 | 6 |
| Rated residual operating current 2 (mA) rms ② | $I_{\Delta N2}$ | - | 15 | 22 | 30 |
| Response time (ms) ③ | Tr | AC: $I_n=1 \cdot I_{\Delta N2}$ | - | 150 | 300 |
| | | AC: $I_n=2 \cdot I_{\Delta N2}$ | - | 90 | 150 |
| | | AC: $I_n=5 \cdot I_{\Delta N2}$ | - | 25 | 10 |
| | | DC: $I_n=1 \cdot I_{\Delta N1}$ | - | 300 | 10000 |
| | | DC: $I_n=10 \cdot I_{\Delta N1}$ | - | 90 | 300 |
| | | DC: $I_n=50 \cdot I_{\Delta N1}$ | - | 25 | 40 |

- ① The negative sign represents the direction of current flow.
- ② Hz=50Hz.
- ③ Interrupting Time according to IEC62752: 5.3.11 Table 2 and 3.

Application Circuit

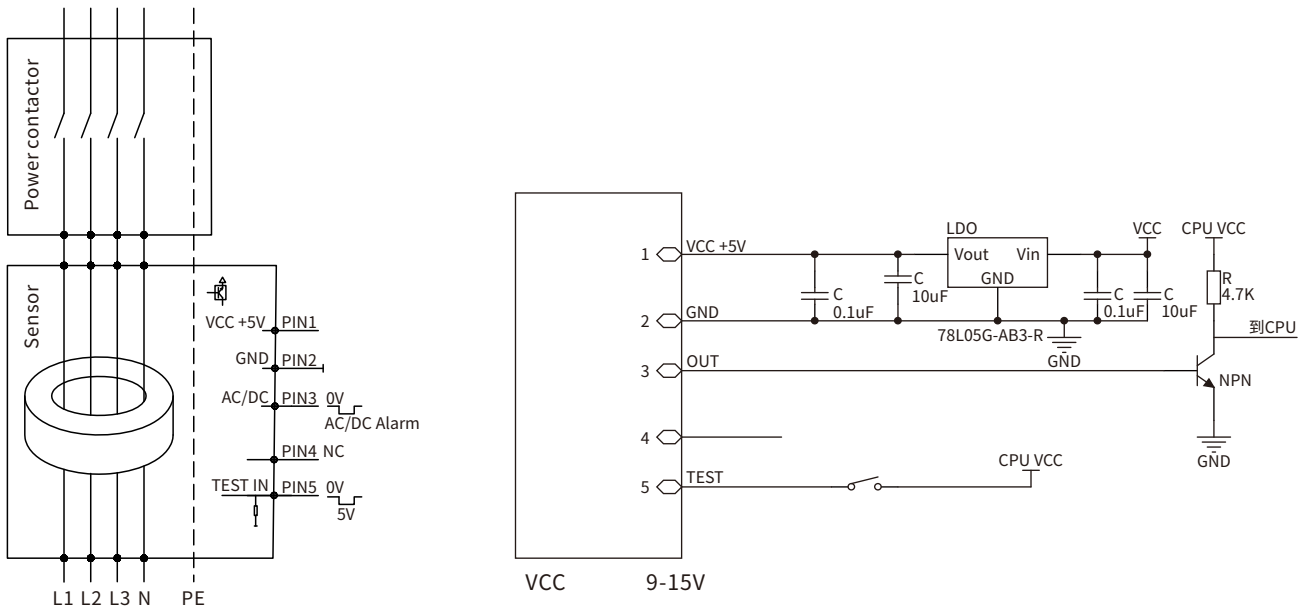

The detection module is sensitive to AC and DC currents and can be used for residual current detection of mode 2 or mode 3 charging equipment. The detection module detects AC and DC fault currents according to the IEC62752/IEC62955 standard requirements. In the case of an AC/DC fault current, PIN3 changes its state from a low level (GND) to a high-level state.

| No. | Symbol | Description |
|-------|--------|----------------------------------------------------------------------------------------------------------------------------------------------------------------------------------------------------------------------------------------------------------------------------------------------------------------------------------|
| PIN-1 | VCC | <ul style="list-style-type: none"> Product power supply pin, standard supply voltage 5V DC. Input voltage range required is 4.8~5.2V DC. |
| PIN-2 | GND | Power ground pin |
| PIN-3 | TRIP | When it is detected that the residual current in the line exceeds the threshold (30mA or 6mA DC), the output level of PIN3 changes from low to high level state, and the driving current is 2mA. |
| PIN-4 | / | NC-Float |
| PIN-5 | TEST | <ul style="list-style-type: none"> Before starting charging, perform a simulation test on the product through this pin to verify whether the product function is normal. If this pin is connected to a high-level state, the functional test is activated (the activation voltage range must be 3V~12V). |

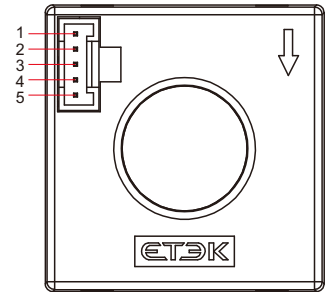

Power Up and Test Mode

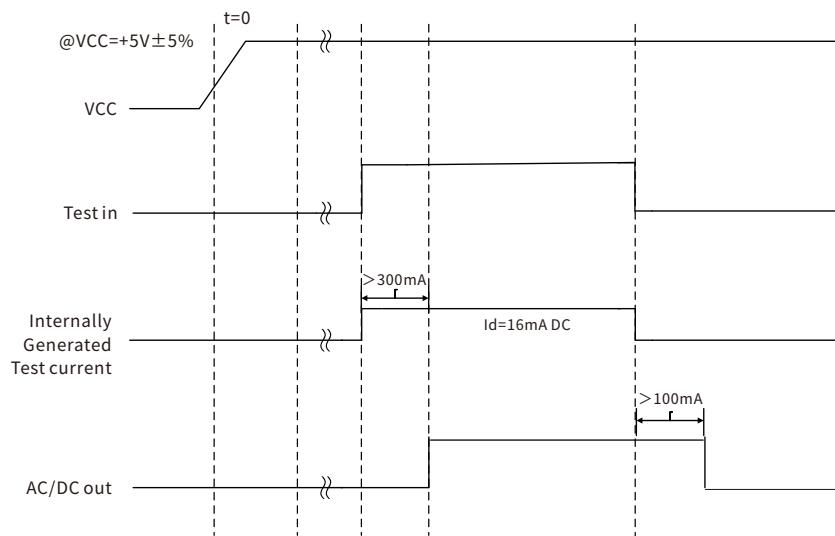

Dimension (mm)

